

SeaHawk LDZB6 Quick Start Guide

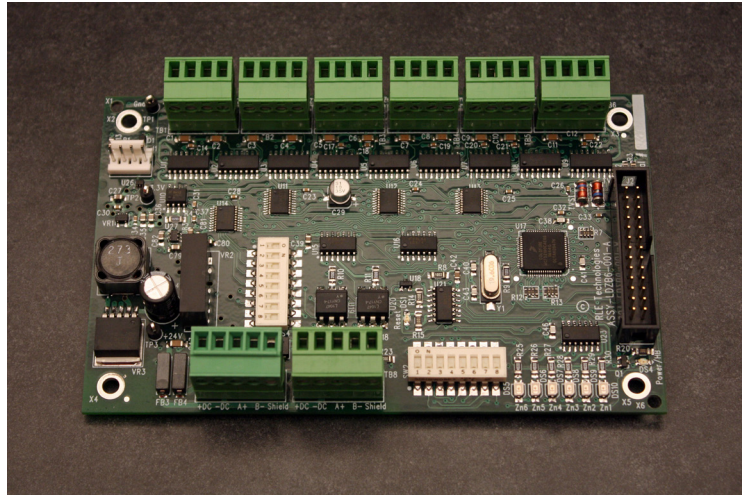

Thank you for purchasing a SeaHawk LDZB6 zone leak detection circuit board. This guide outlines device installation and configuration.

If you need further assistance, please contact RLE Technologies via our website - rletech.com or call us at 800-518-1519.



v2.1
(05/2012)



© Raymond & Lae Engineering, Inc. 2011. All rights reserved. RLE® is a registered trademark and Seahawk™, Falcon™, and Raptor™ are trademarks of Raymond & Lae Engineering, Inc. The products sold by Raymond & Lae Engineering, Inc. are subject to the limited warranty, limited liability, and other terms and conditions of sale set forth at <http://rletech.com/RLE-Terms-and-Conditions.html>.

Supplies for Installation

Available from RLE, sold separately

- Circuit board enclosure
- 24 VDC power supply
- Leader cable for each zone
- SeaHawk sensing cable - up to 500 feet (152.4m) per zone
- End-of-line terminator (EOL) for each zone

Available from Other Vendors

- Electrostatic discharge (ESD) protection

Mount the Device

The LDZB6 does not come with an enclosure or mounting hardware. Use the four provided holes, one in each corner of the circuit board, to secure the board in a suitable enclosure. Mount the enclosure in the desired location.

Connect the Power and Modbus Relay Output

The LDZB6 requires a 9 – 24 VDC power supply. To avoid product damage or personal injury, wire power to the slots labeled **+DC** and **-DC** in the appropriate terminal blocks. If you are using just one LDZB6, use the two left-most pinouts on TB7. If you are using multiple LDZB6s, use TB7 (input) and TB8 (output) to create a daisy-chained power connection. Establish all wiring connections, including power, Modbus, and sensing cable, before you activate the board's power supply.

The LDZB6 is not intended to be used as a stand-alone device. It communicates to a controller via Modbus. If you are installing one LDZB6, use the three right-most pinouts on TB7 to connect to an EIA-485 network. If you are installing more than one LDZB6, use the pinouts on TB7 (input) and TB8 (output) to create a daisy-chained connection. A grounded shield contact is provided for connection to shielded cable. If the shield contact is used, verify the power connector is properly

grounded and there is no voltage potential between units on the Modbus network.

Install the Sensing Cable

Leader cable is used to connect sensing cable to the LDZB6, since sensing cable cannot connect directly to the board. Each zone must have its own leader cable, sensing cable, and end-of-line terminator (EOL).

- Insert the four stripped wires of the leader cable into the appropriate slots in the labeled terminal block at the top of the LDZB6:
 - White wire: insert into pinout labeled **W**
 - Black wire: insert into pinout labeled **B**
 - Green wire: insert into pinout labeled **G**
 - Red wire: insert into pinout labeled **R**
- Unscrew the EOL from the end of the leader cable.
- Attach the first length of sensing cable to the leader cable.
- Route the sensing cable according to your cable layout diagram.
- Secure the EOL to the unoccupied end of the sensing cable.

DIP Switches

The LDZB6 has two sets of DIP switches. SW1 is used to configure the baud rate and termination setting. SW2 is used to set the Modbus address.

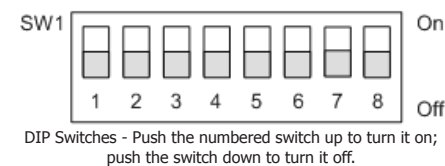

DIP Switch 1, switches 1 through 8		
Set the baud rate for the EIA-485 Port		
1 = Off	2 = Off	Modbus 9600 baud
1 = Off	2 = On	Modbus 1200 baud
1 = On	2 = Off	Modbus 19200 baud
1 = On	2 = On	Modbus 38400 baud
Unused Switches		
DIP Switches 3 - 7	Currently Unused	
EIA-485 Termination Settings		
8 = Off		
8 = On		EIA-485 Termination - Turn this on if you are only using one LDZB6, or if the device is the last unit in a daisy chain.

DIP Switch 2 is used to set the address of the Modbus device, which should be a number between 1 and 254. Adjust the individual switches until their sum equals the Modbus address. If you are daisy-chaining together multiple LDZB6s, each board must have its own unique Modbus address. Switch values are as follows:

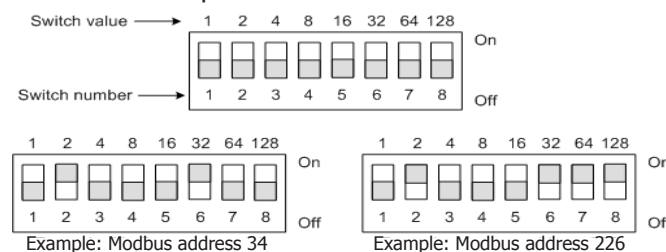

LED Indicators

The LDZB6 contains a series of LEDs. The diagram on the back of this page highlights their locations.

- Heartbeat LED HB - green - blinks - Board is operating normally
- Status LED TX - green - blinks - Board is communicating via Modbus
- Status LED RX - green - blinks - Modbus activity is detected for this board or another board in the daisy-chain
- Alarm LEDs, one labeled for each zone - red - lights - Alarm condition, either leak or cable fault, is detected in the zone.

Modbus Registers

The LDZB6 uses its EIA-485 port to communicate via Modbus. The LDZB6 is configured to act as a slave device on a common network and is a slave only device – it will never initiate a communications sequence.

Modbus register assignments are as follows:

Register Number	Description	Default Value		
Holding Registers				
40001	Leak threshold	60 μ A (Range: 25 - 250 μ A)		
40002 - 40012	not used	0		
40013	Real-time clock days	x		
40014	not used	0		
40015	Real-time clock hours	x		
40016	Real-time clock minutes	x		
40017	Real-time clock days	x		
40018	Leak delay	5 second (Range: 5 - 999 seconds)		
Input Registers				
30001	Leak status bitmap	0 - 15		
Modbus Input Register 30001 Status Flags	Bit	Description	Bit	Description
	00	1 = Zone 1 leak	08	1 = Zone 1 cable break
	01	1 = Zone 2 leak	09	1 = Zone 2 cable break
	02	1 = Zone 3 leak	10	1 = Zone 3 cable break
	03	1 = Zone 4 leak	11	1 = Zone 4 cable break
	04	1 = Zone 5 leak	12	1 = Zone 5 cable break
	05	1 = Zone 6 leak	13	1 = Zone 6 cable break
	06	not used	14	not used
07	not used	15	not used	
30002	Zone 1 leak current	x		
30003	Zone 2 leak current	x		
30004	Zone 3 leak current	x		
30005	Zone 4 leak current	x		
30006	Zone 5 leak current	x		
30007	Zone 6 leak current	x		
30008 -30009	not used	x		
30010	Firmware version	2xx		
30011	Number of zones	6		

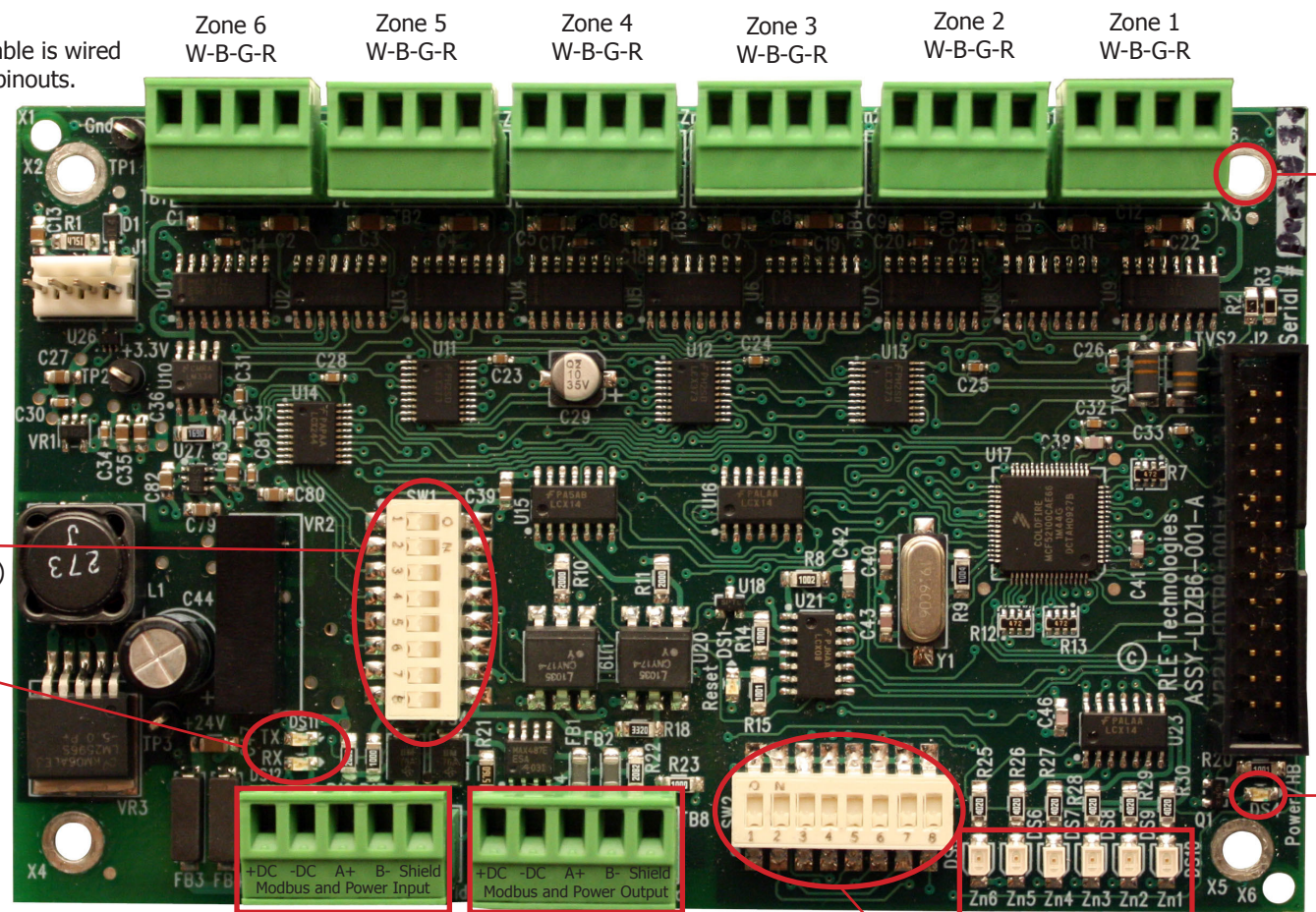
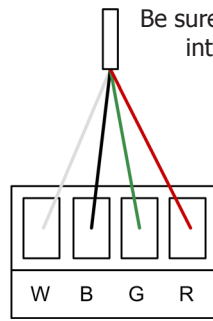

Mounting Holes - One in each corner

SW1
Set the Baud Rate (switches 1 and 2) and Termination Resistor (switch 8)

Modbus Status LEDs
TX - Blinks when the board is communicating via Modbus
RX - Blinks when Modbus activity is detected for this board or any other board in the daisy chain

Heartbeat LED - HB
Indicates device is operating normally

Daisy Chain Wiring Example

Blue lines represent Communications
Use 18 AWG wire

Red lines represent Power
Use 18 AWG twisted pair, shielded, stranded copper wire

Set DIP SW1, switch 8 to OFF.
This signals that this is the last unit in the chain.

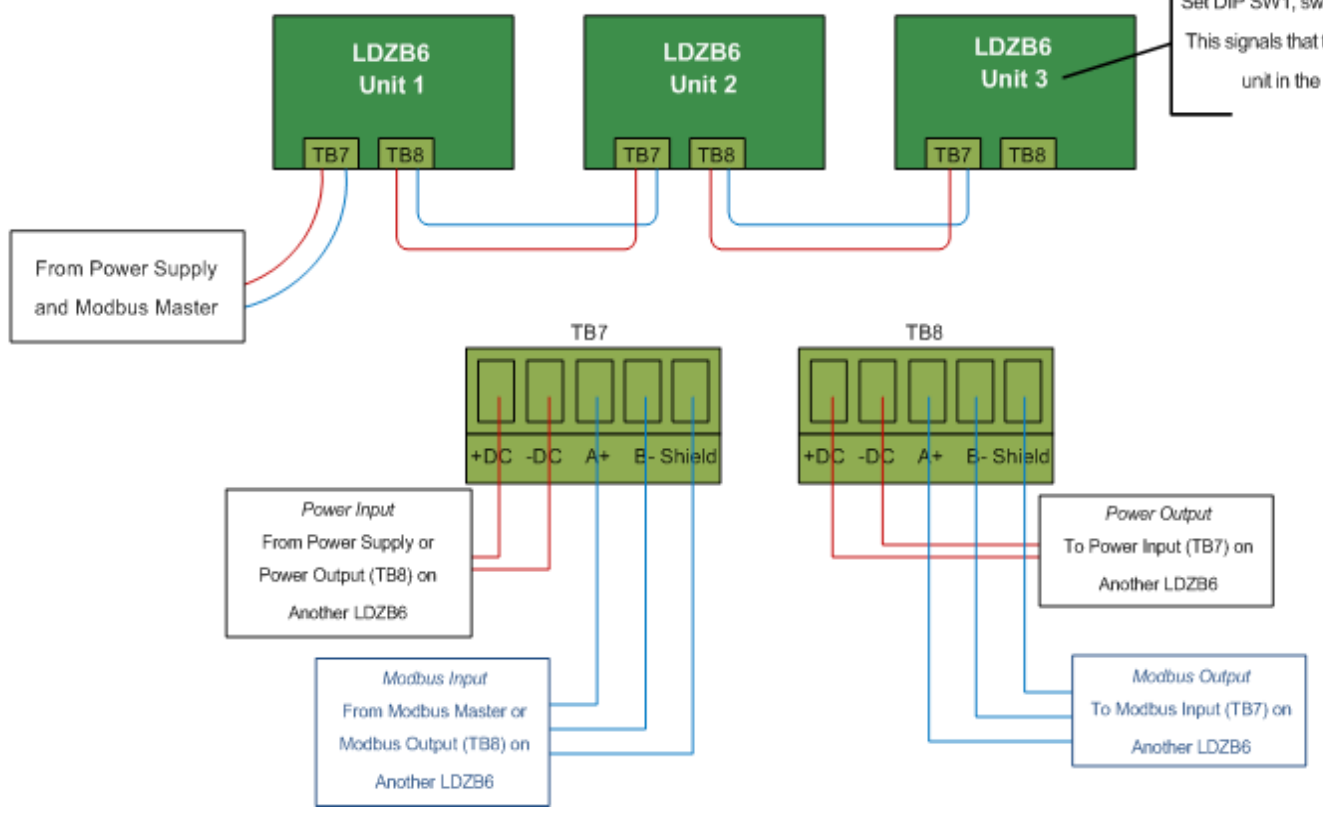

TB7 - Power and Modbus Input
Bring 9-24 VDC power supply and Modbus signal in from original source or another LDZB6 board

TB8 - Power and Modbus Output
Send power and Modbus signal out to another LDZB6 board

SW2
Set the Modbus Address

Alarm LEDs
Zone 6 → Zone 1
One per zone, light when leak or cable break is detected