

Integration

Protocol Converter

User Guide



**Standard
Protocol Converter**



**Dual Port
Protocol Converter**

Copyright and Trademark Notices

© Raymond & Lae Engineering, Inc. 2011. All rights reserved. RLE® is a registered trademark and Seahawk™, Falcon™, and Raptor™ are trademarks of Raymond & Lae Engineering, Inc. The products sold by Raymond & Lae Engineering, Inc. are subject to the limited warranty, limited liability, and other terms and conditions of sale set forth at <http://rletech.com/RLE-Terms-and-Conditions.html>.

Revision History

Rev. No.	Date
1.0	June 2010
1.1	August 2010
1.2	May 2011

Note: As necessary, blank pages are added to make the page count even.

Product Registration

Product registration helps RLE Technologies inform owners of:

- Product upgrades
- Firmware enhancements
- New products and technologies
- Special offers available only to registered users

To submit product registration information for the Protocol Converter, please visit our website:
www.rletech.com.

Any information provided to RLE Technologies through the registration form will be regarded as confidential. RLE will not sell or distribute any of the information to third parties. To read our privacy policy, please visit our website.

Technical Support

Personal assistance is available Monday through Friday, from 8:00 a.m. to 5:00 p.m. MST.

A request for assistance may be sent to support@rletech.com.

Otherwise, please call us directly at: **(970) 484-6510**, and press “2” for technical support.

The following information is located on the bottom of each Protocol Converter unit. Please have this information available whenever a technical support call is placed:

Product Model Number	_____
Product Serial Number	_____
Product Manufacture Date	_____

RLE Product Warranty

Seller warrants to the Ultimate Purchaser (the purchaser who buys for use and not for resale) that all products furnished under this order and which are manufactured by Seller will conform to final specifications, drawings, samples and other written descriptions approved in writing by Seller, and will be free from defects in materials and workmanship. These warranties shall remain in effect for a period of twelve (12) months after shipment. If the Seller installs the equipment or supplies technical direction of installation by contract, said one year shall run from the completion of installation, provided installation is not unreasonably delayed by Ultimate Purchaser. Parts replaced or repaired in the warranty period shall carry the unexpired portion of the original warranty. A unit placed with the purchaser on consignment and then later purchased will be warranted for twelve (12) months from the time the Seller receives notification of the Purchaser's intent to purchase said consigned item. The foregoing is in its entirety is subject to the provision that in no case will the total warranty period extend beyond 18 months from date Seller ships equipment from point of manufacture.

Products are NOT life and safety certified. In no event shall the Seller be liable for loss, damage, or expense directly or indirectly arising from the use of the units, or from any other cause, except as expressly stated in this warranty. Seller makes no warranties, express or implied, including any warranty as to merchantability or fitness for a particular purpose or use. Seller is not liable for and Purchaser waives any right of action it has or may have against Seller for any consequential or special damages arising out of any breach of warranty, and for any damages Purchaser may claim for damage to any property or injury or death to any person arising out of its purchase or the use, operation, or maintenance of the product. Seller will not be liable for any labor subcontracted or performed by Purchaser for preparation of warranted item for return to Seller's factory or for preparation work for field repair or replacement. Invoicing of Seller for labor either performed or subcontracted by Purchaser will not be considered as a liability by the Seller.

The liability of Seller hereunder is limited to replacing or repairing at Seller's factory or on the job site at Seller's option, any part or parts which have been returned to the Seller and which are defective or do not conform to such specifications, drawings or other written descriptions; provided that such part or parts are returned by the Ultimate Purchaser within ninety (90) days after such defect is discovered. The Seller shall have the sole right to determine if the parts are to be repaired at the job site or whether they are to be returned to the factory for repair or replacement. All items returned to Seller for repair or replacement must be sent freight, prepaid to its factory. Purchaser must obtain Seller's Return Goods Authorization prior to returning items. The above conditions must be met if warranty is to be valid. Seller will not be liable for any damage done by unauthorized repair work, unauthorized replacement parts, from any misapplication of the item, or for damage due to accident, abuse, or act of God.

This warranty shall be exclusive of any and all other warranties express or implied and may be modified only by writing signed by any officer of the Seller. This warranty shall extend to the Ultimate Purchaser but to no one else. Accessories supplied by Seller but manufactured by others carry any warranty the manufacturers have made to Seller and which can be passed on to the Ultimate Purchaser.

Seller makes no warranty with respect to whether the products sold hereunder infringe any patent, U.S. or foreign, and Purchaser represents that any specially ordered products do not infringe any patent. Purchaser agrees to indemnify and hold Seller harmless from any liability by virtue of any patent claims where Purchaser has ordered a product conforming to Purchaser's specifications, or conforming to Purchaser's specific design.

Purchaser has not relied and shall not rely on any oral representation regarding the Product sold hereunder and any oral representation shall not bind Seller and shall not be part of any warranty.

Contents

- 1 System Overview 11**
 - Introduction 11
 - Product Description 11
 - Rear Panel Indicators 11
 - Terminal Block Designations 13
 - SW1 Switch Settings 14

- 2 Installation 15**
 - Registering the Protocol Converter 15
 - Mounting the Protocol Converter 16
 - Wiring the Protocol Converter 17
 - Protocol Converter Power Supply and Ground Connections 17
 - RJ45 Ethernet Connection 18
 - EIA-232 COM Connection 19
 - Modbus EIA-485 Connections 19

- 3 Configuration 21**
 - Configuring Communication 22
 - Set the IP Address Using a Web Browser 22
 - Set the IP Address Using an EIA-232 Connection 24
 - Logging in to the Protocol Converter 26
 - Accessing Help 27
 - Configuring Slave Devices 27
 - Configuring Device Registers 29
 - Enabling Write Operations to Devices 29
 - Accessing the Register Configuration Webpages 30
 - Deleting All Registers 31
 - Modbus Register Configuration 32
 - SNMP Register Configuration 35
 - BACnet Register Configuration 38
 - Configuring Network and Web Properties 41
 - Setting and Synchronizing the Clock 42
 - Clock 42
 - Network Time Protocol (NTP) 43
 - Setting Communication Protocol Options 44
 - Modbus/EIA-485 Port Configuration 44
 - BACnet Server Configuration 46
 - SNMP 48
 - SMTP (Email) 49

- 4 Operation 51**

- 5 Modbus Communications 53**
 - Implementation Basics 53
 - Modes of Transmission 53
 - Slave Address Field 53
 - Function Field 54

Data Field	54
Error Check (Checksum) Field	54
Exception Responses	54
Packet Communications for the Protocol Converter	54
Function 03: Read Output Registers	54
RTU Framing	55
A Loading Firmware and Configuration Files	57
Loading Flash Firmware Using MIME	57
Loading Flash Firmware Using TFTP	59
Saving a Configuration (.cfg) File	61
Loading a Configuration (.cfg) File	62
Saving a Device Configuration (.xml) File	63
Loading a Device Configuration (.xml) File	64
B Troubleshooting	67
C Technical Specifications	69

Figures

1	System Overview	11
	Figure 1.1 Location of Indicators	12
	Figure 1.2 Locations of Terminals	13
2	Installation	15
	Figure 2.1 Mounting Brackets	16
	Figure 2.2 24VDC Power Supply Connection	17
	Figure 2.3 Protocol Converter Ethernet Connection to a PC Using a Crossover Cable. . .	18
	Figure 2.4 Protocol Converter Ethernet Connection to a PC on a Subnet. . .	18
	Figure 2.5 EIA-232 COM Connection. . .	19
	Figure 2.6 EIA-485 Connection	19
3	Configuration	21
	Figure 3.1 Example Home Page	26
	Figure 3.2 Help Page	27
	Figure 3.3 Device Configuration. . .	27
	Figure 3.4 Register Configuration Page. . .	30
	Figure 3.5 Example Register Link Page. . .	30
	Figure 3.6 System Page—Delete All Registers	31
	Figure 3.7 Modbus Register Configuration. . .	32
	Figure 3.8 Modbus “Manual Preset Single Register” Link	34
	Figure 3.9 Modbus Preset Single Register Webpage	34
	Figure 3.10 SNMP Register Configuration. . .	35
	Figure 3.11 “SNMP Set Register” Link	37
	Figure 3.12 SNMP “New Value” Field	37
	Figure 3.13 BACnet Register Configuration. . .	38
	Figure 3.14 BACnet “Write Value” Link	40
	Figure 3.15 BACnet “Analog Value Write” Field. . .	40
	Figure 3.16 Network and Web Configuration	41
	Figure 3.17 Clock Configuration. . .	42
	Figure 3.18 Network Time Protocol (NTP) Configuration. . .	43
	Figure 3.19 Modbus/Device Configuration	44
	Figure 3.20 BACnet Server Configuration	46
	Figure 3.21 Example BACnet PICS Page	47
	Figure 3.22 SNMP Server Configuration	48
	Figure 3.23 SMTP Configuration	49
4	Operation	51
	Figure 4.1 Protocol Converter Devices (Home) Page	51
	Figure 4.2 Color Codes for the Home Page	52
	Figure 4.3 Register Status Example. . .	52

A	Loading Firmware and Configuration Files	57
	Figure A.1 System Page—Load Flash Firmware	58
	Figure A.2 Choosing a Firmware File	58
	Figure A.3 Firmware Load Messages	58
	Figure A.4 Identity Link Showing Current Firmware Version	59
	Figure A.5 System Page	59
	Figure A.6 Bootloader Page	60
	Figure A.7 System Page—Download Configuration File	61
	Figure A.8 Example Download .cfg	61
	Figure A.9 System Page	62
	Figure A.10 Device Configuration Link in Top Bar	63
	Figure A.11 Device Configuration Webpage	63
	Figure A.12 Device Configuration Link in Top Bar	64
	Figure A.13 Device Configuration Webpage	64
	Figure A.14 XML Upload Dialog	65
	Figure A.15 Preset/Delete Link on Device Configuration Webpage	65
	Figure A.16 Preset/Delete Dialog	65
	Figure A.17 Drop-Down for Preset/Delete Dialog	66

Tables

1	System Overview	11
	Table 1.1 LED Indicator Descriptions	12
	Table 1.2 Terminal Block Designations	13
	Table 1.3 Status Indicator Descriptions	14
3	Configuration	21
	Table 3.1 Device Configuration Fields	28
	Table 3.2 Modbus Register Configuration Page Fields	33
	Table 3.3 SNMP Register Configuration Fields	36
	Table 3.4 BACnet Register Configuration Fields	39
	Table 3.5 Network and Web Configuration Fields	41
	Table 3.6 Clock Fields	42
	Table 3.7 NTP (Network Time Protocol) Fields	43
	Table 3.8 Modbus/Device Configuration Fields	45
	Table 3.9 BACnet Server Fields	47
	Table 3.10 SNMP Configuration Fields	48
	Table 3.11 SMTP Configuration Fields	50
5	Modbus Communications	53
	Table 5.1 Exception Codes	54
	Table 5.2 Read Output Registers Packet Structure	55
	Table 5.3 Output Registers	55
	Table 5.4 Response Sample	55
B	Troubleshooting	67
	Table B.1 Troubleshooting the Protocol Converter	67
C	Technical Specifications	69
	Table C.1 Technical Specifications	69

Notes:

SYSTEM OVERVIEW

1.1. Introduction

This manual describes how to install the Raptor™ FDS-PC Protocol Converter and configure it to communicate using the Modbus, BACnet, and SNMP protocols.

IMPORTANT Basic configuration to install the hardware and connect the Protocol Converter to the network is available from RLE. However, the Protocol Converter is an advanced product, and you must have in-depth knowledge of the Modbus, BACnet, and SNMP protocols to complete the configuration. If needed, you can purchase advanced support from RLE by contacting support@rletech.com or calling 970.484.6510, Option 2.

1.2. Product Description

The FDS-PC Protocol Converter receives one or more protocol types and outputs up to three protocol types. The Protocol Converter can receive data from slave devices using Modbus RTU, Modbus TCP/IP, BACnet/IP, or SNMP (integer data). The Protocol Converter can then be polled by a master unit via SNMP, Modbus RTU, Modbus TCP/IP, or BACnet/IP. In addition, the Dual Port Protocol Converter can be configured as a slave (**Note:** only as a slave) and polled by a master unit via BACnet MS/TP.

There are two versions of the Protocol Converter: the “standard” version, and the “dual port” version, which contains two additional EIA-485 ports for expanded connectivity and communication.

1.2.1 Rear Panel Indicators

The back of the Protocol Converter has the following indicators:

- ◆ Two indicators to show when data is being transmitted and received through the EIA-485 port (the Dual Port Protocol Converter contains three EIA-485 ports and three sets of transmit-receive indicators). When data is either being transmitted or received, the status lights will blink. If no information is being communicated, the lights are off.
- ◆ One status indicator to show when the Protocol Converter is booting up or has an alarm condition. If neither of these is occurring, the light is off.

Figure 1.1 on page 12 illustrates these two sets of indicators.

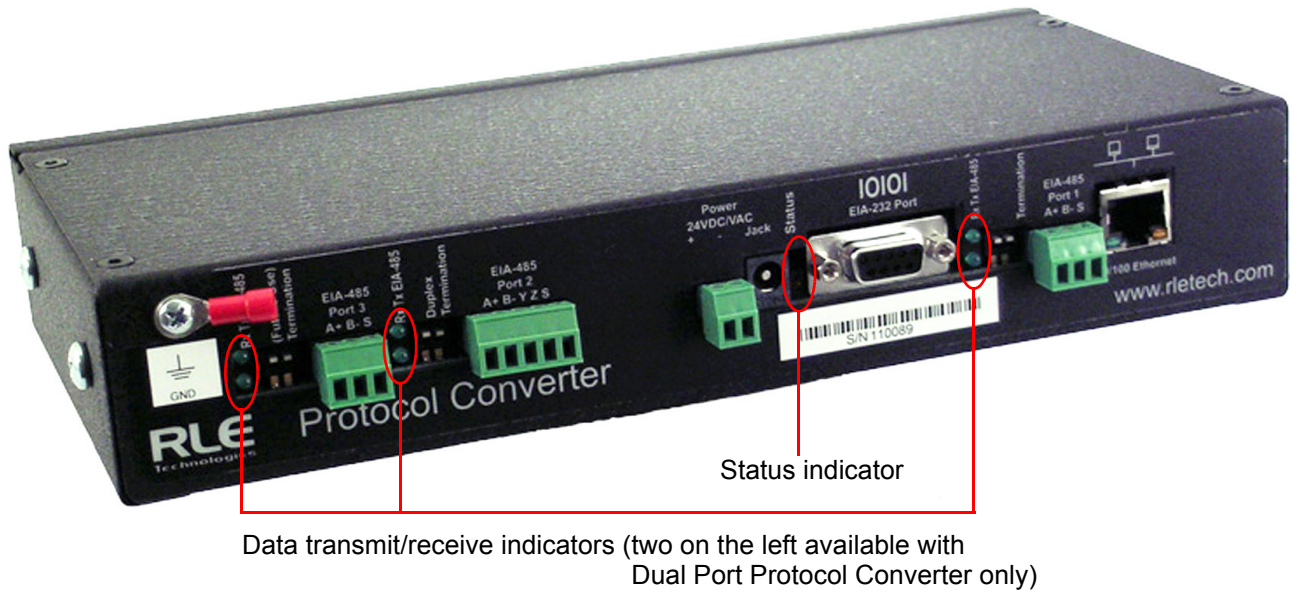

Figure 1.1 Location of Indicators

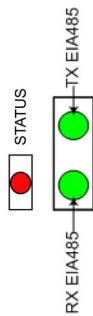

Table 1.1 LED Indicator Descriptions

Status	Indicator
Status LED	Flashing red: Boot-up sequence
	Solid red: Alarm condition
EIA-485 TX	Flashing: Data is being transmitted.
EIA-485 RX	Flashing: Data is being received.

1.2.2 Terminal Block Designations

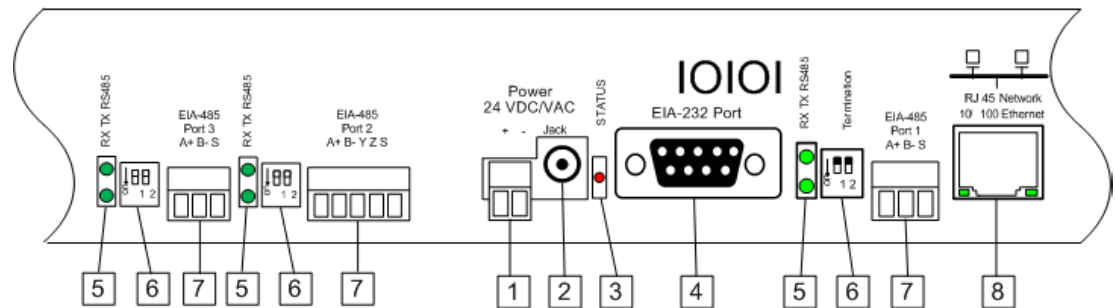

Figure 1.2 Locations of Terminals

Table 1.2 Terminal Block Designations

Item No.	Item	Description
1	Power 24 VDC/VAC	Power terminal block
2	Jack	Power connector for wall wart adapter
3	Status	Status LED
4	EIA-232 Port	DB9 female connector
5	RX TX EIA-485 LED	Receive/Transmit status LED. Dual Port Protocol Converter contains two additional sets of LEDs.
6	EIA-485 Termination switch	Dual Port Protocol Converter contains two additional sets of switches; EIA-485 Port 2, the 5-pin port, can be configured as a 2-wire (half-duplex) or 4-wire (full-duplex) connection. Ports 1 and 3: Switch 1 - unused; Switch 2 - On = 100 Ohm termination Port 2: Switch 1 -Duplex (On = 4-wire; Off = 2-wire); Switch 2 - On = 100 Ohm termination
7	EIA-485 port	Dual Port Protocol Converter contains two additional EIA-485 ports. Port 2 (the middle port) can be configured as a 2-wire or 4-wire connection. In addition to all other supported protocols, Port 3 (the left most port) of the Dual Port Protocol Converter is BACnet MS/TP capable (<i>Slave only</i>).
8	RJ45 Ethernet port	10/100 BaseT connector

1.2.3 SW1 Switch Settings

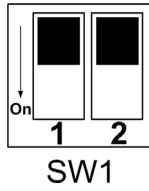

Table 1.3 Status Indicator Descriptions

Switch	Setting
SW1-1	Dual Port Protocol Converter only: Duplex (On = 4-wire; Off = 2-wire)
SW1-2	EIA-485 Termination (On=100 Ohm termination)

INSTALLATION

Installing the Protocol Converter involves the following:

- 1 Registering the Protocol Converter on the RLE Web site
- 2 Mounting the Protocol Converter and making the necessary wiring and cabling connections
- 3 Connecting the power
- 4 Setting the IP address

2.1. Registering the Protocol Converter

Go to <http://www.rletech.com/product-registration.html> and enter the requested information. Click the Register button to register your product.

2.2. Mounting the Protocol Converter

The Protocol Converter comes with mounting brackets to allow the unit to be installed in a 19-inch (0.48m) rack.

- 1 Using the screws provided, attach the mounting brackets to the sides of the Protocol Converter.
- 2 Install the Protocol Converter in the rack.
- 3 Use the proper anchoring method to mount the Protocol Converter securely.



Figure 2.1 Mounting Brackets

Note: If necessary, the brackets can be reversed so the other side of the Protocol Converter is facing outward.

2.3. Wiring the Protocol Converter

If you plan to use the EIA-485 port for Modbus RTU communication, RLE Technologies recommends an 18 AWG shielded, twisted-pair stranded copper wire for the connection. RLE recommends no more than 2,000 feet (609.6m) of wire at this specification. If longer runs are needed, contact RLE Technologies for application guidance.

2.3.1 Protocol Converter Power Supply and Ground Connections

To provide power and ground connections to the Protocol Converter:

- 1 Connect an 18 AWG ground wire from the ground terminal to a suitable earth ground.
- 2 Connect power to the Protocol Converter in one of two ways, as shown in Figure 2.2:
 - a Plug the wall adapter (provided) into the power jack on the Protocol Converter and into a UPS outlet.
 - b Connect a dedicated 24VDC power supply to the + and - terminals to the left of the power jack.

IMPORTANT RLE Technologies recommends powering the Protocol Converter from a UPS (uninterruptible power supply) so the Protocol Converter can send alarm notifications during a power outage.

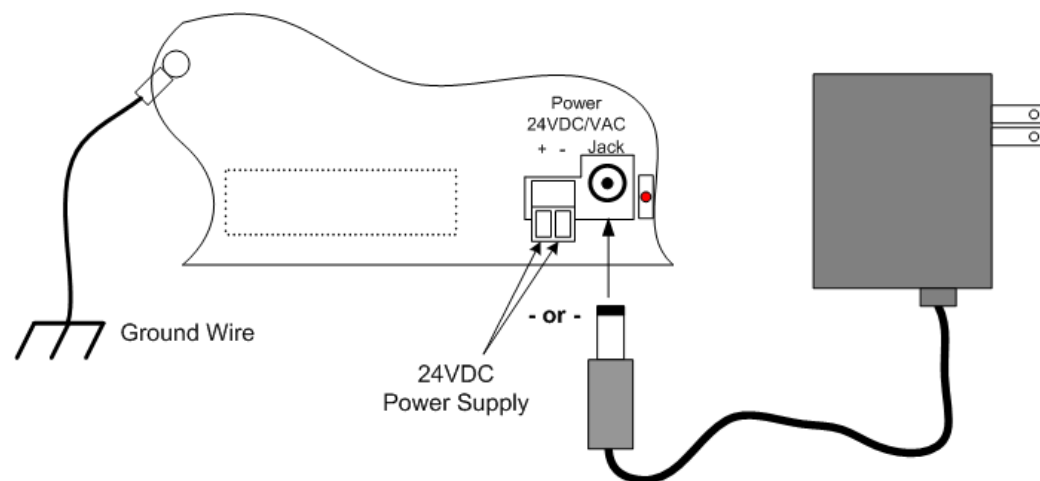

Figure 2.2 24VDC Power Supply Connection

2.3.2 RJ45 Ethernet Connection

The Protocol Converter has an internal 10/100BaseT Ethernet port used to configure the Protocol Converter. The Ethernet port supports Web browser access, BACnet, Modbus, SNMP, and SMTP (email).

Direct Connection

To make a direct connection between the Protocol Converter and a computer or laptop using the crossover cable (the blue cable with yellow connectors provided with the Protocol Converter). See [Figure 2.3](#).

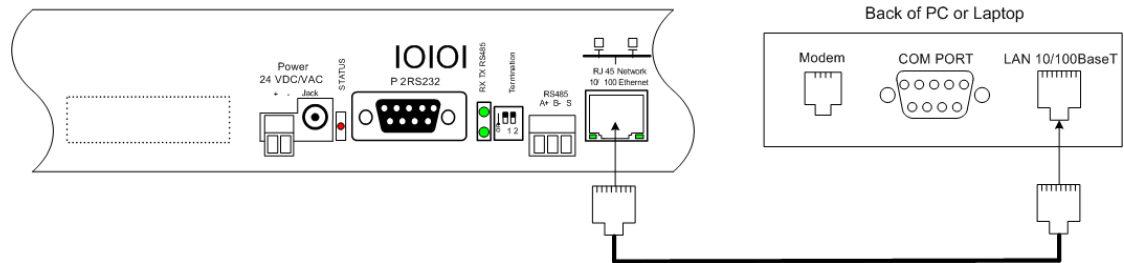

Figure 2.3 Protocol Converter Ethernet Connection to a PC Using a Crossover Cable

Subnet Connection

To connect the Protocol Converter on a subnet using a hub or switch and straight-through CAT5 cables, see [Figure 2.4](#) for an example of a typical connection.

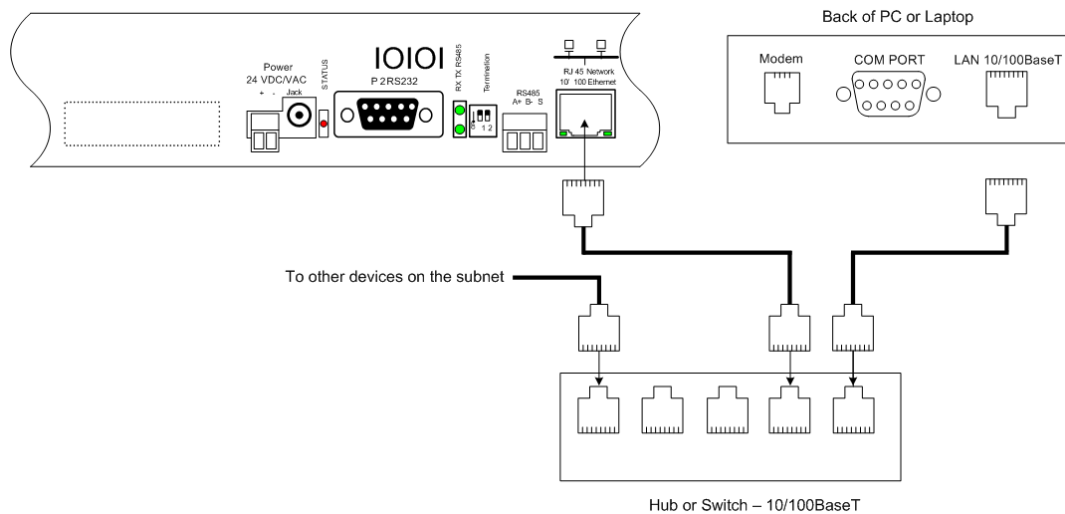

Figure 2.4 Protocol Converter Ethernet Connection to a PC on a Subnet

2.3.3 EIA-232 COM Connection

The EIA-232 port can be connected to a PC for IP configuration, firmware downloads, and troubleshooting.

Note The EIA-232 is typically only used as a temporary connection.

Connect the straight through, 9-pin, serial cable as shown in [Figure 2.5](#).

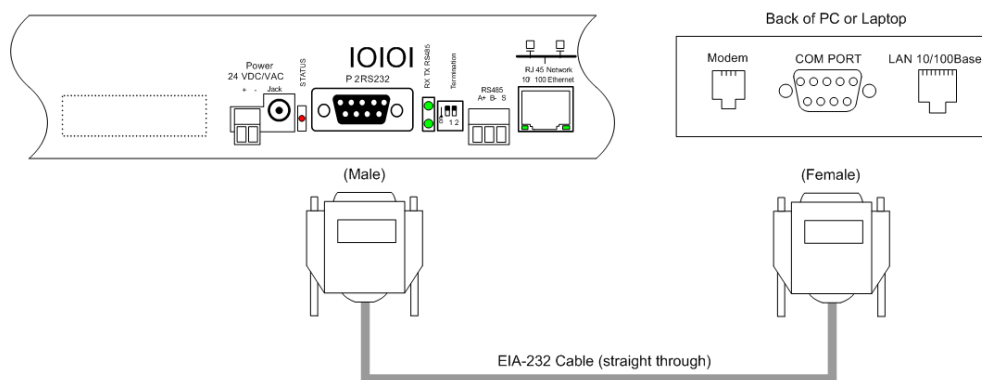

Figure 2.5 EIA-232 COM Connection

2.3.4 Modbus EIA-485 Connections

The Protocol Converter can function as a Modbus Slave or Modbus Master over an EIA-485 hardware connection. The Dual Port Protocol Converter contains three EIA-485 ports, and EIA-485 Port 2 can be configured as either a 2-wire or 4-wire connection by wiring the port appropriately and turning on the Duplex DIP switch. See [Table 1.2](#) and [Table 1.3](#) on [page 14](#) for information about configuring this port.

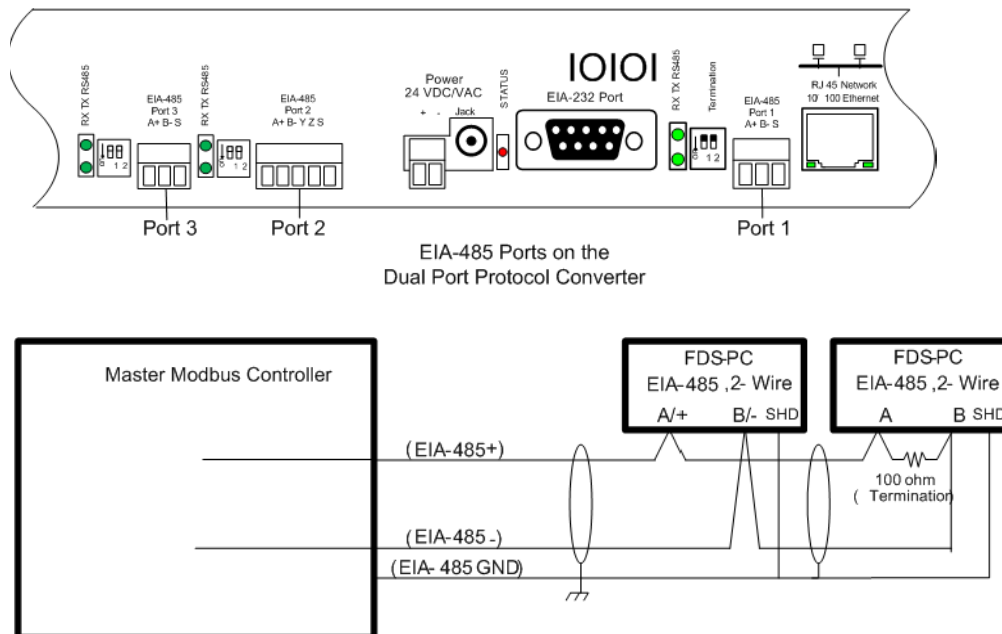

Figure 2.6 EIA-485 Connection

Notes:

CONFIGURATION

The Protocol Converter allows you to view and configure slave devices and slave registers over the Web. To access the Web interface, you must first set up the Protocol Converter to communicate over the Internet. To set the IP address, see [“Configuring Communication”](#) on page 22.

Follow the order of the sections in this chapter to completely configure the slave devices, registers, and the Protocol Converter.

3.1. Configuring Communication

The Protocol Converter will not communicate over a user's network the first time it is connected to the network. At the factory, the Protocol Converter is set with a default IP address of 10.0.0.188 and Subnet Mask: 255.255.255.0.

You must change this default address to an IP address that corresponds with your network before the Protocol Converter can communicate over the network. Use one of these vehicles to change the IP address:

- ◆ A Web browser
- ◆ The EIA-232 interface

3.1.1 Set the IP Address Using a Web Browser



WARNING

Unless you are familiar with setting the IP address, consult your IT department before attempting this procedure.

To use a Web browser to set the Protocol Converter's IP address:

- 1 Plug a crossover network cable into the laptop or workstation that will be used to configure the Protocol Converter.
- 2 Write down the computer's current IP address and Subnet Mask.

IMPORTANT You will need to change the computer's IP address and Subnet Mask back to the original settings after changing the IP address and Subnet Mask for the Protocol Converter.

- 3 Change the IP address and Subnet Mask of the computer from its existing address to one that will allow it to communicate with the Protocol Converter, such as 10.0.0.180.

Note It may be beneficial to set the IP address to one that is one number different from the Protocol Converter's IP address. Consult the computer's manual or your IT department before attempting this procedure.

- 4 Connect the other end of the network cable to the Ethernet port on the back of the Protocol Converter.
- 5 Access the Protocol Converter through a Web browser by typing the IP address (10.0.0.188) into the location bar.

- 6 When prompted, enter the Protocol Converter user name (fds). There is no default password; leave this field blank.

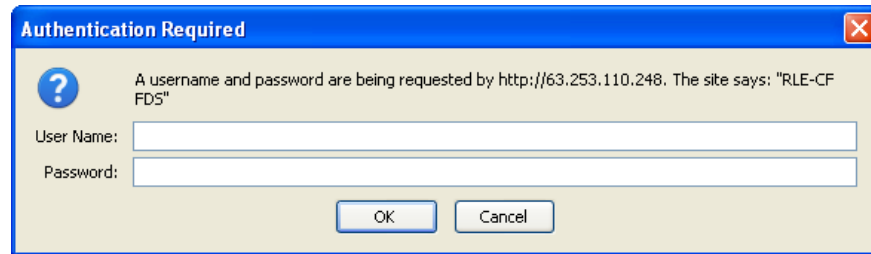

Authentication Required

A username and password are being requested by http://63.253.110.248. The site says: "RLE-CF FDS"

User Name:

Password:

OK Cancel

Once you enter the correct user name, the Home page displays.

- 7 Select the **Configuration** link from the top bar, then select the Network and Web link from the Configuration menu.

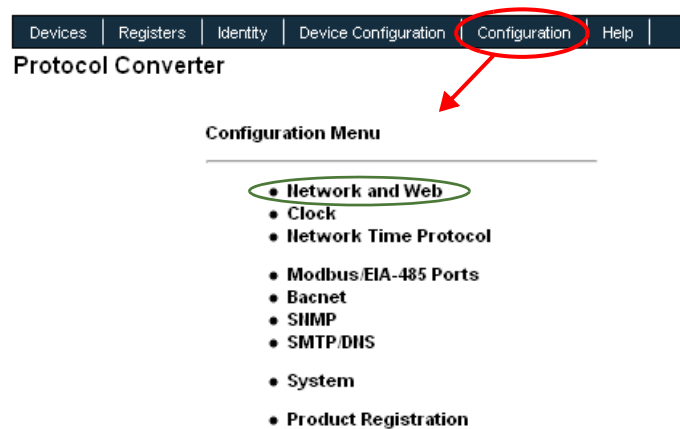

- 8 On the Network and Web page, change the IP address, Subnet Mask (Net Mask), and Default Gateway (Def Route) to one provided by your network administrator.

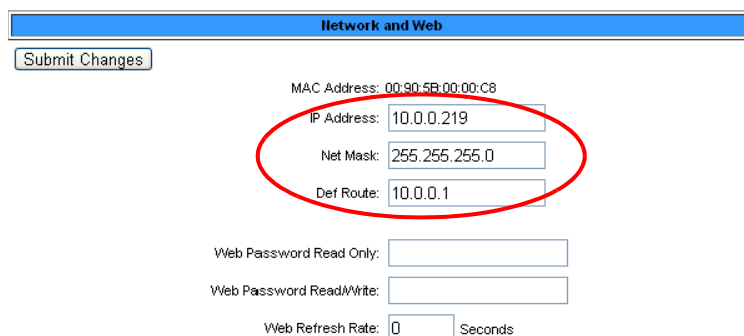

Network and Web

Submit Changes

MAC Address: 00:90:5B:00:00:C8

IP Address:

Net Mask:

Def Route:

Web Password Read Only:

Web Password Read/Write:

Web Refresh Rate: Seconds

- 9 Press the **Submit Changes** button.

The Protocol Converter saves the new IP address, Subnet Mask, and default Gateway and then reboots.

- 10 Change the IP address of the computer back to its original IP address.

- 11 If the computer was configured as DHCP (the network domain controller assigns an IP address) return it to this state. This procedure might require assistance from your IT department, or you might need to consult the computer's manual.

The computer and the Protocol Converter are both configured to communicate on the network. Both should be accessible via the network.

- 12 Connect the computer and the Protocol Converter to the network.

- 13 From the computer's Web browser, type the new IP address of the Protocol Converter. Enter the user name and password as stated in [step 6](#) to verify network access to the Protocol Converter.

3.1.2 Set the IP Address Using an EIA-232 Connection

To use the EIA-232 interface to set the Protocol Converter's IP address:

- 1 Connect the EIA-232 port on the Protocol Converter to a terminal or PC running terminal emulation software (HyperTerminal) with a 9-pin, male-female, straight-through serial cable.
- 2 Set the appropriate communication port to 9600 baud, no parity, 8 data bits, 1 stop bit, (9600/N/8/1), and no software or hardware flow command.
- 3 Once the terminal emulation software starts, press **Enter** on the keyboard.

The Protocol Converter's boot prompt appears, (FDS_PC>).

Note If the Protocol Converter's boot prompt does not appear, check the communication settings and make sure the unit is powered on.

- 4 From the boot prompt, type IP, one space, and the new IP address for the Protocol Converter, then press **Enter**.

Example:

```
IP 192.168.103.211
```

The Protocol Converter reboots after the IP address is changed.

- 5 *If you need to change the subnet mask:* From the boot prompt type NM, one space, and the new Subnet Mask address for the FDS-PC, then press Enter.

Example:

```
NM 255.255.255.0
```

The Protocol Converter reboots after the Subnet Mask is changed.

- 6 *If you need to change the default gateway:* From the boot prompt, type DG, one space, and the Default Gateway address for the Protocol Converter, then press Enter.

Example:

```
DG 192.168.103.1
```

The Protocol Converter reboots after the Default Gateway is changed.

The Protocol Converter IP address is now set, and it can be accessed through a Web browser using the new IP address. The default username is fds. There is no password; leave that field blank.

3.2. Logging in to the Protocol Converter

Once the IP address for the Protocol Converter has been set as described in 3.1., “Configuring Communication” on page 22, you can log in to the device to configure it (or to view slave device status if configuration has already been completed).

To log in to the Protocol Converter:

- 1 Open a Web browser and type the Protocol Converter’s IP address (default is 10.0.0.188) into the location bar.
- 2 When prompted, enter the Protocol Converter user name (default is fds).

Note: There is no default password; if you have not set a password, leave this field blank.

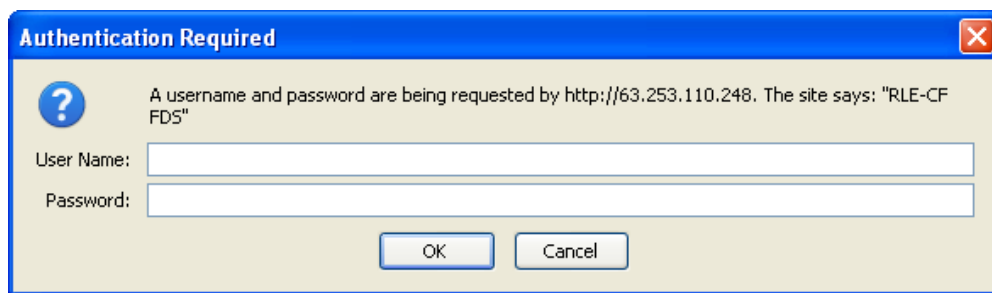

Once you enter the correct user name (and password), the Home page displays. An example of the Home page is shown in Figure 3.1.

#	Name	Access
1	I/O Module	Modbus/485
2	LD2100.1	Modbus/TCP
3	LD2100.2	Modbus/TCP
4		Modbus/485
5		Modbus/485
6		Modbus/485
7		Modbus/485
8		Modbus/485
9		Modbus/485
10		Modbus/485
11		Modbus/485
12		Modbus/485
13		Modbus/485
14		Modbus/485
15		Modbus/485
16		Modbus/485
17		Modbus/485
18		Modbus/485
19		Modbus/485
20		Modbus/485
21		Modbus/485
22		Modbus/485
23		Modbus/485
24		Modbus/485
25		Modbus/485
26		Modbus/485
27		Modbus/485
28		Modbus/485
29		Modbus/485
30		Modbus/485
31		Modbus/485
32		Modbus/TCP

Figure 3.1 Example Home Page

3.3. Accessing Help

Once you have logged in to the Protocol Converter's user interface, you can view the Help page any time. This webpage shows a color key for the device status information on the Home page and directs you to the RLE website at www.rletech.com. See [Figure 3.2](#).

For more advanced troubleshooting refer to the user guide. All product documentation is available online at www.rletech.com.

If you are still experiencing difficulties, contact your local representative.

Color Code for the homepage:

Color	Meaning
(Green)	Register is communicating properly
(Red)	Register has reached an alarm threshold
(Orange)	Register is offline - problems with the communications
(Yellow)	Register - pending alarm
(Yellow)	IP device - no arp response

Figure 3.2 Help Page

3.4. Configuring Slave Devices

You can configure up to 32 slave devices to the Protocol Converter. To configure slave devices:

- 1 From the Home page of the Protocol Converter's user interface, click the Device Configuration link in the top bar.

The Device Configuration page displays.

The screenshot shows the 'Protocol Converter' user interface with the 'Device Configuration' tab selected. The page displays four configuration panels for slave devices:

- Device #1:** Access Mode: Modbus-RTU/485, EIA-485 Port: 1, Modbus Slave Address / Unit Identifier: 2, IP Address: 0.0.0.0, Device Name: ALC I/O.
- Device #2:** Access Mode: SNMP, EIA-485 Port: 1, Modbus Slave Address / Unit Identifier: 0, IP Address: 66.214.208.134, Device Name: Sentry Switched CDU, Snmp Community / Bacnet Device Instance: public.
- Device #5:** Access Mode: Modbus-RTU/485, EIA-485 Port: 1, Modbus Slave Address / Unit Identifier: 0, IP Address: 0.0.0.0.
- Device #6:** Access Mode: Modbus-RTU/485, EIA-485 Port: 1, Modbus Slave Address / Unit Identifier: 0, IP Address: 0.0.0.0.

Figure 3.3 Device Configuration

The Device Configuration page is made up of four subpages with eight slave devices per page. These slave devices can be configured for Modbus RTU/485, Modbus TCP/IP, BACnet/IP or SNMP.

- 2 To configure a slave device, enter the appropriate information for the communication protocol used by that device.

For example, enter the unit's slave address (Modbus), IP address, a device name, and SNMP Community or BACnet device instance (device number), depending on which applies to that slave device.

- 3 Repeat step2 for each slave device you want to configure.
- 4 If desired, use the Download XML link located in each device configuration box to save the device configuration and copy it to another device. Use the Upload XML link to upload the configuration to another device. See “Saving a Device Configuration (.xml) File” on page 63 and “Loading a Device Configuration (.xml) File” on page 64 for details.

The fields on the Device Configuration webpage are described in Table 3.1.

Table 3.1 Device Configuration Fields

Field	Description/
Access Mode	Use the drop-down to select Modbus-RTU/485, Modbus TCP, SNMP, BACnet/IP, or RFC-1628. Note: RFC-1628 access mode is available for BACnet/IP only.
Modbus Slave Address / Unit Identifier	A numeric value that indicates the slave address for Modbus communications. Type an integer ranging from 1 to 254. If Modbus communications will not be used, leave this value at 0.
IP Address	The IP address of the device being polled for Modbus TCP/IP, SNMP, or BACnet/IP slave data.
Device Name	An alphanumeric value (label) of your choice that identifies the slave device being polled. This label can contain up to 30 characters.
SNMP Community / BACnet Device Instance	A value that defines the SNMP community/string to be used for obtaining data or the BACnet device instance number or Device ID number assigned to the slave unit. For BACnet, this value is numeric. For SNMP, this value is alphanumeric.

3.5. Configuring Device Registers

Once the desired slave devices have been configured on the Protocol Converter, you can program registers to those slave devices for the proper information to be polled. First, you can select whether or not to enable write operations to the slave devices, then you can program the registers.

Note: You can also delete the Protocol Converter's entire register set. Make sure to consider this operation carefully before carrying it out.

3.5.1 Enabling Write Operations to Devices

1 To enable the ability to write values to Modbus, SNMP, and BACnet device registers:

- a From any webpage in the Protocol Converter's user interface, click the Configuration link in the top bar.

The Configuration menu displays.

Configuration Menu

- Network and Web
- Clock
- Network Time Protocol
- **Modbus/EIA-485 Ports**
- BACnet
- SIIMP
- SMTP/DHS
- System
- Product Registration

- b Select EIA-485/Modbus/BACnet-MSTP Ports from the menu.

The Modbus/EIA-485/BACnet-MSTP Port webpage displays.

Modbus/EIA-485/BACnet-Mstp Port

Submit Changes

Modbus/TCP/UDP Slave Unit Identifier: 1 (1-254, 0 = disabled)

Offline Startup Delay: 5 (minutes)

Max Device Response Time: 1.0 (0.3-9.9 seconds)

SNMP/BACnetIP Device Poll Rate: 10 Packets Per Second

Device Write Enable: Yes No

- c Select Yes for Device Write Enable in the first section of this webpage.

The write operations are generated via Modbus preset single-register commands, SNMP sets, and BACnet write-property operations. Refer to the following sections on configuration Modbus, SNMP, and BACnet registers for more information about generating write operations using the Protocol Converter's user interface.

3.5.2 Accessing the Register Configuration Webpages

- 2 Access the Register Configuration page by clicking on the Registers link in the top bar.

The Register Configuration page displays.

Total Registers : 14	Page 1 of 32	Jump to page: <input type="text" value="--"/>
----------------------	--------------	---

#	Name	Device	Register	Value	Age
1	AC1 Current	1	40001	0.000000	?
2	AC2 Current	1	40003	0.000000	?
3	Hallway Temperature	1	40005	0.000000	?
4	Room Humidity	1	40007	0.000000	?
5	Room Temperature	1	40009	0.000000	?
6	Underfloor Temperature	1	40011	0.000000	?
7	AC1 Airflow	1	10001	0	?
8	AC2 Airflow	1	10002	0	?
9	Utility Power	1	10003	0	?
10	Utility Lost	1	10008	0	?
11	AC1 Fail to Start	1	10009	0	?
12	AC1 No Airflow	1	10010	0	?
13	AC2 Fail to Start	1	10011	0	?
14	AC2 No Airflow	1	10012	0	?
15		0	---	0	?
16		0	---	0	?

#	Name	Device	Register	Value	Age
17		0	---	0	?
18		0	---	0	?
19		0	---	0	?
20		0	---	0	?
21		0	---	0	?
22		0	---	0	?
23		0	---	0	?
24		0	---	0	?
25		0	---	0	?
26		0	---	0	?
27		0	---	0	?
28		0	---	0	?
29		0	---	0	?
30		0	---	0	?
31		0	---	0	?
32		0	---	0	?

Figure 3.4 Register Configuration Page

- 3 Click on the register number to configure individual registers.

#	Name	Device	Register	Value	Age
1	AC1 Current	1	40001	0.000000	?
2	AC2 Current	1	40003	0.000000	?
3	Hallway Temperature	1	40005	0.000000	?
4	Room Humidity	1	40007	0.000000	?

Figure 3.5 Example Register Link Page

The configuration page for that register displays. Notice that the Unit number corresponds to the Device number listed on the Register Link page.

- 4 Enter the necessary information for the register type you are configuring. See Sections 3.5.4 to 3.5.6 for more information.
- 5 Click Submit.

The Protocol Converter updates the information and displays the information that applies to that unit (Modbus, SNMP, or BACnet).

3.5.3 Deleting All Registers

If you need to reconfigure the Protocol Converter for a new application, you can delete the entire register set.

IMPORTANT Consider the Delete All Registers option carefully and use it with caution. You should use this option only if you need to reconfigure the Protocol Converter for a new application.

To delete all programmed registers:

- 1 In the user interface, go to Configuration>System.

The System webpage displays.

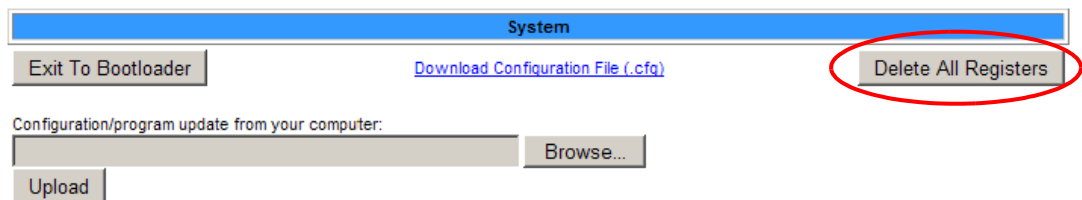

Figure 3.6 System Page—Delete All Registers

- 2 Click the Delete All Registers button.

A pop-up displays so you can confirm the delete operation.

- 3 If you are certain you want to delete all programmed registers, click OK. Otherwise, click Cancel.

When you click OK, the registers are immediately deleted.

3.5.4 Modbus Register Configuration

If you are configuring a Modbus device, the register configuration page looks like this:

Figure 3.7 Modbus Register Configuration

To set values:

- 1 Type an appropriate value in each field, or choose the value from the drop-down. See [Table 3.2 on page 33](#) for more information.
- 2 Click Submit Changes located in the upper left hand corner of the web page.
- 3 Once the changes have been accepted, click the Next>> link at the bottom of the page.

You can also click the First, <<Prev, Last, or End links to go to those locations in the list of registers.

The following table describes the fields on the Modbus Register Configuration page.

Table 3.2 Modbus Register Configuration Page Fields

Field	Description
Modbus Register	The Modbus register to be polled by the Protocol Converter to that specific slave. The Protocol Converter can poll Coil registers (1x,) Status registers (2x), Input registers (3x), and Holding registers (4x). Type a value in the range of 10000 to 49999.
Register Type	The register type. Choose Unsigned Integer, Signed integer, Long, Float, Alarm Bit / ON=ALARM, Alarm Bit / OFF=ALARM, Status Bit - No Log, Status Bit - Logged, Coil Status, or Input Status.
Bitflag	The proper bit flag to be used for this particular register. Choose values from :00 to :15.
Modbus Word Order	Determines the way the register is read by the Protocol Converter. Choose from Big-Endian (Left to Right) or Little-Endian (Right to Left).
Gain	The gain value of the raw data being received. Set this value only if necessary.
Offset	The offset value to the calculated reading for the register. Set this value only if necessary.
Label	A name (label) for the register being configured. Labels can be up to 30 alphanumeric characters in length.
HTML Display	Allows you to choose how the value is displayed on the register page. Choose from Integer (whole number) or Float (number plus decimal).
Threshold 1	Indicates the value that, when reached or exceeded, causes the Protocol Converter to trigger an alarm. This value can be configured as less than (<), Equal to (=) or greater than (>).
Threshold 2	Indicates the value that, when reached or exceeded, causes the Protocol Converter to trigger an alarm. This value can be configured as less than (<), Equal to (=) or greater than (>).
Alarm Delay	The amount of time, in seconds, after an alarm condition arises before the Protocol Converter triggers an alarm. The default value of 0 indicates no delay.
Offline Delay	The amount of time, in seconds, that elapses before the Protocol Converter considers the register to be stalled or offline. The default value of 0 indicates no delay.
Current Age	Indicates the amount of time, in seconds, since the Protocol Converter last received an updated value.
Local Modbus Int Register	The Modbus Integer data (whole number) used by a master device polling the Protocol Converter.
Local Modbus Float Register	The Modbus Float data (number with decimal) used by a master device polling the Protocol Converter.
BACnet Instance	The number used by a BACnet master for polling data from the Protocol Converter. Possible values include Analog Instance (AI) or Binary Instance (BI).

Table 3.2 Modbus Register Configuration Page Fields (continued)

Field	Description
BACnet COV Client (COV - Change of Value)	The IP address of the BACnet master that is polling the FDS-PC.
BACnet COV SPID	Subscriber Process Identifier. Also, select the Confirmed or Unconfirmed radio button to indicate
BACnet COV Increment	Amount that the present value of a point needs to change before the COV is initiated to the BACnet master.
BACnet COV Period	Interval, in seconds, between polling operations.
SNMP register/Table OIDs	The OID (object identifier) being polled from the SNMP software. The Protocol Converter displays the OIDs used for Integer data, Float data, and the Label assigned.
SNMP Modbus Device Register/Table OIDs	Formatted to BASE.DEVICENUMBER.REGISTERNUMBER where BASE is the OID for this table, DEVICENUMBER is the device's number in the Protocol Converter (1-32) and the REGISTERNUMBER reflects the appropriate device point address.

- Write a specific value to a Modbus register by clicking the Manual Preset Single Register link on the individual register pages.

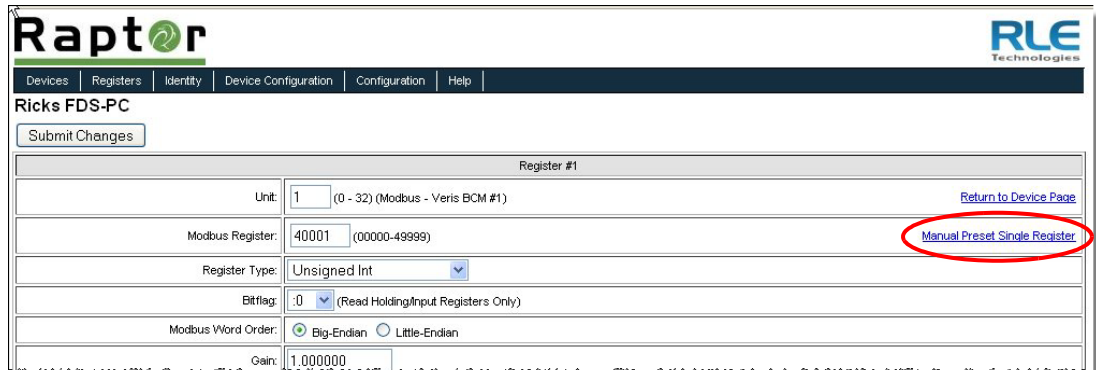

Figure 3.8 Modbus “Manual Preset Single Register” Link

When you click this link, the Modbus Preset Single Register webpage displays.

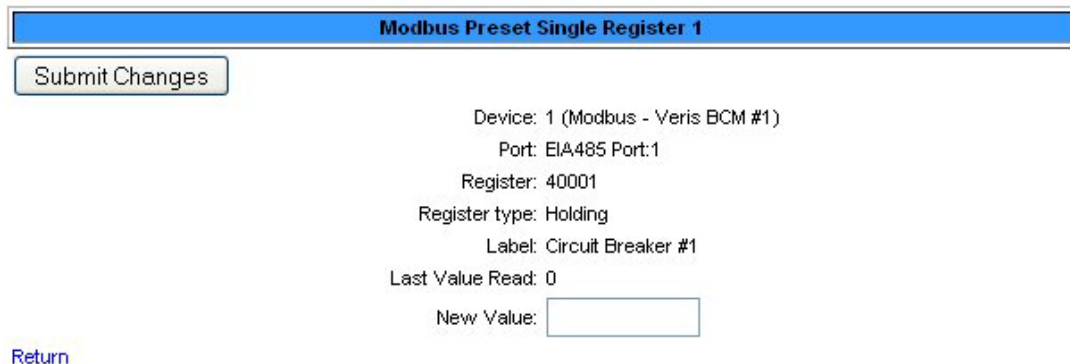

Figure 3.9 Modbus Preset Single Register Webpage

- 5 Enter the new value for the register in the New Value box and click the Submit Changes button.

You can click the Return link to go back to the register configuration page.

3.5.5 SNMP Register Configuration

If you are configuring an SNMP device, the register configuration page looks like this:

Register #1	
Unit:	2 (0 - 32) (Snmp - Falcon F110)
Snmp Get OID:	(object-syntax: 0)
OID Type:	Signed Int
Gain:	1.000000
Offset:	0
Label:	Leak Detected
Html Display:	<input checked="" type="radio"/> Integer <input type="radio"/> Float
Threshold 1:	0 Is Greater Than
Threshold 2:	0 Is Greater Than
Alarm Delay:	0 (Seconds)
Offline Delay:	0 (Seconds) (0=Disable Offline Alarms)
Current Age:	3
Local Modbus Int Register:	40001: 0
Local Modbus Float Register:	42001: 0.000000
Bacnet Instance:	ai:1
Bacnet COV Client:	0.0.0.0 Last SubscribeCOV Time: ""
Bacnet COV SPID:	0 <input checked="" type="radio"/> Unconfirmed <input type="radio"/> Confirmed
Bacnet COV Increment:	1.000000
Bacnet COV Period:	0 (0-65535 Seconds)
Snmp registerTable Oids:	int data: 1.3.6.1.4.1.3184.1.10.3.2.1.1.2.1 float data: 1.3.6.1.4.1.3184.1.10.3.2.1.1.3.1 label: 1.3.6.1.4.1.3184.1.10.3.2.1.1.4.1
Snmp modbusDeviceRegisterTable Oids:	

Figure 3.10 SNMP Register Configuration

To set values:

- 1 Type an appropriate value in each field, or choose the value from the drop-down. See [Table 3.3 on page 36](#) for more information.
- 2 Click Submit Changes located in the upper left hand corner of the web page.
- 3 Once the changes have been accepted, click on Next>> link at the bottom of the page.

You can also click the First, <<Prev, Last, or End links to go to those locations in the list of registers.

The following table describes the field on the SNMP Register Configuration page.

Table 3.3 SNMP Register Configuration Fields

Field	Description
SNMP Get OID	The OID (object identifier) the Protocol Converter uses to gather the correct integer data from the SNMP device being polled.
OID Type	The object identifier type. Currently, the Protocol Converter can poll Integer data.
Gain	The gain value of the raw data being received (set only if necessary).
Offset	The offset value of the calculated reading to the register.
Label	A value (label) for the register being configured. Labels can contain up to 30 alphanumeric characters.
HTML Display	Allows you to choose how the value is displayed on the register page. Choose from Integer (whole number) or Float (number plus decimal).
Threshold 1	The value that, when reached or exceeded, causes the Protocol Converter to trigger an alarm. This value can be configured as less than (<), Equal to (=) or greater than (>).
Threshold 2	The value that, when reached or exceeded, causes the Protocol Converter to trigger an alarm. This value can be configured as less than (<), Equal to (=) or greater than (>).
Alarm Delay	The amount of time, in seconds, after an alarm condition arises before the Protocol Converter triggers an alarm. The default value of 0 indicates no delay.
Offline Delay	The amount of time, in seconds, that elapses before the Protocol Converter considers the register to be stalled or offline. The default value of 0 indicates no delay.
Current Age	Indicates the amount of time, in seconds, since the Protocol Converter last received an updated value.
Local Modbus Int Register	The Modbus Integer data (whole number) used by a master device polling the Protocol Converter.
Local Modbus Float Register	The Modbus Float data (number with decimal) used by a master device polling the Protocol Converter.
BACnet Instance	The number used by a BACnet master for polling data from the Protocol Converter. Possible values include Analog Instance (AI) or Binary Instance (BI).
SNMP register/Table OIDs	The OID (Object Identifier) being polled from a SNMP software. The Protocol Converter displays the OIDs used for Integer data, Float data and the Label assigned.
SNMP modbus Device Register/Table OID	Formatted to BASE.DEVICENUMBER.REGISTERNUMBER where BASE is the OID for this table, DEVICENUMBER is the device's number in the Protocol Converter (1-32) and the REGISTERNUMBER reflects the appropriate device point address.

- Write a specific value to an SNMP register by clicking the SNMP Set Register link on the individual register pages.

The screenshot shows the Raptor web interface for configuring Register #21. The page title is "Ricks FDS-PC". A "Submit Changes" button is visible. The configuration table includes the following fields:

Register #21	
Unit:	5 (0 - 32) (Snmp - Liebert UPS) Return to Device Page
Snmp Get OID:	1.3.6.1.2.1.33.1.9.7.0 (object-syntax: integer 88) Snmp Set Register
OID Type:	Signed Int
Gain:	1.000000
Offset:	0
Label:	lowBattTime

Figure 3.11 "SNMP Set Register" Link

When you click this link, the SNMP Set Register webpage displays.

The screenshot shows the "SNMP Set Register 21" webpage. It includes a "Submit Changes" button and the following information:

Device: 5 (Snmp - Liebert UPS)
 Port: Ethernet
 Snmp Set OID: 1.3.6.1.2.1.33.1.9.7.0 (object-syntax: integer 88)
 Type: Integer
 Label: lowBattTime
 Last Value Read: 88
 New Value:

[Return](#)

Figure 3.12 SNMP "New Value" Field

- Enter the new value for the register in the New Value box and click the Submit Changes button.

You can click the Return link to go back to the register configuration page.

3.5.6 BACnet Register Configuration

If you are configuring a BACnet device, the register configuration page looks like this:

[Submit Changes](#)

Register #1	
Unit:	3 (0 - 32) (BacnetMP - FalconLite)
Bacnet Instance:	30001 (Device Updates:0 Errors:0 Rejects:0)
Instance Type:	Analog Output
Gain:	1.000000
Offset:	0
Label:	Leak Detected
Html Display:	<input checked="" type="radio"/> Integer <input type="radio"/> Float
Threshold 1:	0 Is Greater Than
Threshold 2:	0 Is Greater Than
Alarm Delay:	0 (Seconds)
Offline Delay:	0 (Seconds) (0=Disable Offline Alarms)
Current Age:	45
Local Modbus Int Register:	40001: 0
Local Modbus Float Register:	42001: 0.000000
Bacnet Instance:	ai:1
Bacnet COV Client:	0.0.0.0 Last SubscribeCOV Time: ""
Bacnet COV SPID:	0 <input checked="" type="radio"/> Unconfirmed <input type="radio"/> Confirmed
Bacnet COV Increment:	1.000000
Bacnet COV Period:	0 (0-85535 Seconds)
Snmpr registerTable Oids:	int data: 1.3.6.1.4.1.3184.1.10.3.2.1.1.2.1 float data: 1.3.6.1.4.1.3184.1.10.3.2.1.1.3.1 label: 1.3.6.1.4.1.3184.1.10.3.2.1.1.4.1
Snmpr modbusDeviceRegisterTable Oids:	

Figure 3.13 BACnet Register Configuration

To set values:

- 1 Type an appropriate value in each field, or choose the value from the drop-down. See [Table 3.4 on page 39](#) for more information.
- 2 Click [Submit Changes](#) located in the upper left hand corner of the web page.
- 3 Once the changes have been accepted, click on [Next>>](#) link at the bottom of the page.

You can also click the [First](#), [<<Prev](#), [Last](#), or [End](#) links to go to those locations in the list of registers.

The following table describes the fields on the BACnet Register Configuration webpage.

Table 3.4 BACnet Register Configuration Fields

Field	Description
BACnet Instance	The Instance number used by the Protocol Converter to poll the desired data from that BACnet device.
Instance Type	The type of BACnet instance. From the drop-down, choose Analog Input (AI), Analog Output (AO), Analog Value (AV), Binary Input (BI), Binary Output (BO), or Binary Value (BV).
Gain	The gain value of the raw data being received if needed. Calculate as follows: $(\text{Sensor High Range Value} - \text{Sensor Low Range Value}) / 4$
Offset	The offset value of the calculated reading to the register. Calculate as follows: $\text{Sensor Low Range Value} - \text{Gain}$
Label	A value (label) for the register being configured. Labels can contain up to 30 alphanumeric characters.
HTML Display	Allows you to choose how the value is displayed on the register page. Choose from Integer (whole number) or Float (number plus decimal).
Threshold 1	The value that, when reached or exceeded, causes the Protocol Converter to trigger an alarm. This value can be configured as less than (<), Equal to (=) or greater than (>).
Threshold 2	The value that, when reached or exceeded, causes the Protocol Converter to trigger an alarm. This value can be configured as less than (<), Equal to (=) or greater than (>).
Alarm Delay	The amount of time, in seconds, after an alarm condition arises before the Protocol Converter triggers an alarm. The default value of 0 indicates no delay.
Offline Delay	The amount of time, in seconds, that elapses before the Protocol Converter considers the register to be stalled or offline. The default value of 0 indicates no delay.
Current Age	Indicates the amount of time, in seconds, since the Protocol Converter last received an updated value.
Local Modbus Int Register	The Modbus Integer data (whole number) used by a master device polling the Protocol Converter.
Local Modbus Float Register	The Modbus Float data (number with decimal) used by a master device polling the Protocol Converter.
BACnet Instance	The number used by a BACnet master for polling data from the Protocol Converter. Possible values include Analog Instance (AI) or Binary Instance (BI).
SNMP register/Table OID	The OID (Object Identifier) being polled from a SNMP software. The Protocol Converter displays the OIDs used for Integer data, Float data and the Label assigned.
SNMP modbus Device Register/Table OID	Formatted to BASE.DEVICENUMBER.REGISTERNUMBER where BASE is the OID for this table, DEVICENUMBER is the device's number in the Protocol Converter (1-32) and the REGISTERNUMBER reflects the appropriate device point address.

- 4 Write a specific value to a BACnet register by clicking the Write Value link on the individual register pages.



Figure 3.14 BACnet “Write Value” Link

When you click this link, the BACnet Analog Value Write webpage displays.

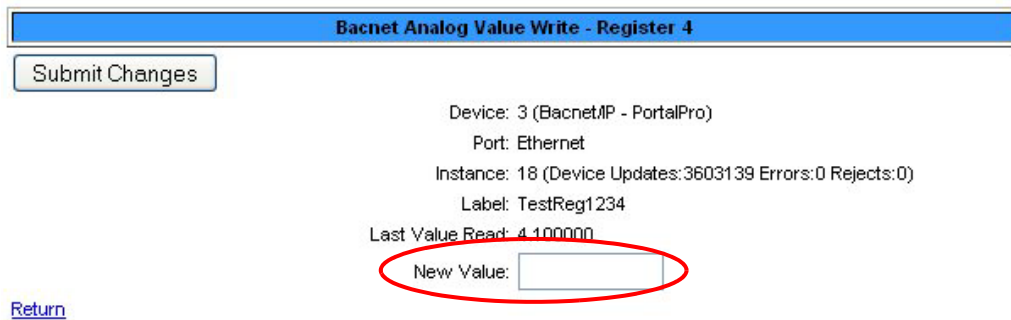

Figure 3.15 BACnet “Analog Value Write” Field

- 5 Enter the new value for the register in the New Value box and click the Submit Changes button.

You can click the Return link to go back to the register configuration page.

3.6. Configuring Network and Web Properties

The Network and Web section displays the MAC address and allows you to fill in the IP Address, Net Mask, Default Router (Default Gateway), Passwords, and Refresh rate. To configure these items:

- 1 In the user interface, go to Configuration>Network and Web.

The Network and Web configuration page displays.

The screenshot shows the 'Network and Web' configuration page. At the top, there is a blue header bar with the text 'Network and Web'. Below the header is a 'Submit Changes' button. The configuration fields are: MAC Address: 00:90:5B:00:00:C8; IP Address: 10.0.0.219; Net Mask: 255.255.255.0; Def Route: 10.0.0.1; Web Password Read Only: (empty field); Web Password Read/Write: (empty field); Web Refresh Rate: 0 Seconds.

Figure 3.16 Network and Web Configuration

- 2 Set the fields as described in [Table 3.5](#).

Table 3.5 Network and Web Configuration Fields

Field	Description
IP Address	The Protocol Converter is configured at the factory with a default IP Address of 10.0.0.188.
Net (Subnet) Mask	The Protocol Converter is configured at the factory with a default Subnet Mask of 255.255.255.0.
Def (Default) Route	The Protocol Converter is configured at the factory with a default Gateway Route of 10.0.0.1. To modify the Gateway Route, contact the IT department for these settings.
Web Password Read Only	An alphanumeric value of 16 characters maximum. Enter a password so you can access the Protocol Converter Web interface and view the conditions of the sensors.
Web Password Read/Write	An alphanumeric value of 16 characters maximum. Enter a password so you can view the condition of the sensors and make changes to the Protocol Converter configuration.
Web Refresh Rate	This integer value represents how long the system waits until it updates the Web interface with current data. To change the rate, click in the field and type the desired amount of time (in seconds). The default refresh rate is set to 0, which means the Protocol Converter will not refresh at all. If you want the system to automatically refresh, set the refresh rate to a positive number greater than 0. The minimum recommended refresh rate is five seconds. A slower rate could cause errors that prevent the system from functioning properly.

3.7. Setting and Synchronizing the Clock

Set the synchronize the Protocol Converter's clock to ensure that all time-stamped events are accurate and reliable.

3.7.1 Clock

To set the clock:

- 1 In the user interface, go to Configuration>Clock.

The Clock configuration webpage displays.

Figure 3.17 Clock Configuration

- 2 Set the current date and time as described in Table 3.6.

Table 3.6 Clock Fields

Field	Description
Date	Enter the date in mm/dd/yy format.
Time	Enter the time in hh:mm:ss format (24-hour clock).

3.7.2 Network Time Protocol (NTP)

Network Time Protocol (NTP) is widely used on the Internet to synchronize computer clocks to national standard time or Coordinated Universal Time (UTC). NTP synchronizes the time of a computer or server (in this case, the Protocol Converter) to another server or referenced time source. NTP is important for maintaining a high level of accuracy and reliability in time stamped events.

To synchronize the clock:

- 1 In the user interface, go to Configuration>NTP.

The Network Time Protocol (NTP) Configuration page displays.

NTP

Network Time (NTP) Server: (IP address or hostname)

Update Interval: (5-1440 Minutes - 0 for disabled)

Select Time Zone: ▼

Daylight Savings Time: ▼

DST Begin Date: ▼

DST End Date: ▼

Ntp server Ip Addr: 192.43.244.18

```

sysUpTime (/100): 2245
LastNtpRequestTime: 2136
LastNtpResponseTime: 2136
NextNtpRequestTime: 2436
LastTransmitTimestamp: D016A80F
Last Ntp Update: 08/18/10 12:42:23 DST (UTC -7 + 1)

```

Figure 3.18 Network Time Protocol (NTP) Configuration

- 2 Set the NTP options as described in [Table 3.7](#).

Table 3.7 NTP (Network Time Protocol) Fields

Field	Description
Network Time (NTP) Server	The IP address or hostname of the Network Time Protocol Server with which the Protocol Converter will synchronize. Examples of public NTP Servers include us.pool.ntp.org and time.nist.gov.
Update Interval	The time in minutes the Protocol Converter takes to request time updates from the NTP Server. This can be set from 5 to 1440 minutes. Enter 0 to disable.
Select Time Zone	Select the time zone in which the Protocol Converter resides.
Daylight Savings Time	Select the hour Daylight Savings Time occurs. Typically, this is 2:00 A.M. local time.
DST Begin Date	Enter the date Daylight Savings Time will begin.
DST End Date	Enter the date Daylight Savings Time will end.

3.8. Setting Communication Protocol Options

Set the Modbus, BACnet, or SNMP protocols as described in the following sections.

3.8.1 Modbus/EIA-485 Port Configuration

To configure the Modbus/EIA-485 port:

- 1 In the user interface, go to Configuration>EIA-485/Modbus/BACnet-MSTP Ports.

The Modbus/EIA-485/BACnet-MSTP Port webpage displays.

Modbus EIA-485 Bacnet-Mstp Port

Submit Changes

Modbus/TCP/UDP Slave Unit Identifier: (1-254, 0 = disabled)

Offline Startup Delay: (minutes)

Max Device Response Time: (0.3-9.9 seconds)

SNMP/BacnetIP Device Poll Rate: Packets Per Second

Device Write Enable: Yes No

EIA-485 Port1 Function:

EIA-485 Port1 Baud Rate:

EIA-485 Port1 Parity: None Even Odd

EIA-485 Port1 Stop Bits: 1 2

EIA-485 Port1 Slave Address: (1-254, 0 = disabled)

EIA-485 Port2 Function:

EIA-485 Port2 Baud Rate:

EIA-485 Port2 Parity: None Even Odd

EIA-485 Port2 Stop Bits: 1 2

EIA-485 Port2 Slave Address: (1-254, 0 = disabled)

EIA-485 Port3 Function:

EIA-485 Port3 Baud Rate:

EIA-485 Port3 Parity: None Even Odd

EIA-485 Port3 Stop Bits: 1 2

EIA-485 Port3 Slave Address: (1-254, 0 = disabled)

Bacnet-MS/TP Port3 Max Master:

```

48001 device enabled register (32bit) data: 80000007
48003 device in alarm register (32bit) data: 00000000
48005 device offline register (32bit) data: 00000000

```

Figure 3.19 Modbus/Device Configuration

- 2 Configure the appropriate ports as described in Table 3.8 on page 45.

Table 3.8 Modbus/Device Configuration Fields

Field	Description
Modbus/TCP/UDP Slave Unit Identifier	TCP/UDP slave address in the range 1 to 254. To disable this feature, leave the address set to 0.
Offline Startup Delay	Amount of time, in minutes, that the Protocol Converter waits before considering any slave device as offline after a power up.
Max. Device Response Time	Determines the allowable response time, in seconds, from devices before the Protocol Converter times out. Set a value in the range of 1 to 9. If the Protocol Converter times out, an offline alarm is triggered and the device's status color changes on the Home page.
SNMP/BACnet/IP Device Poll Rate	Determines the rate, in packets per second, at which data is sent. The drop-down provides selections of 1, 5, or 10.
Device Write Enable	Determines whether or not client write operations to the Protocol Converter are translated, written to the specific server device or register and then read back by the Protocol Converter to update the local register data. The write operations are generated via SNMP Sets, BACnet Write-Property and Modbus Preset Single Register commands. Select Yes to enable the Protocol Converter to perform write operations. Default: Yes.
EIA-485 Port (1, 2, 3) Function	The port type for the EIA-485 port. Choose Modbus Slave or Modbus Master.
EIA-485 Port (1, 2, 3) Baud Rate	Speed of the EIA-485 port. Choose 1200, 2400, 9600 (default), or 19200. Ports 2 and 3 can also run at 38400 baud.
EIA-485 Port (1, 2, 3) Parity	Select None (default), Even, or Odd for the Parity output.
EIA-485 Port (1, 2, 3) Stop Bits	Select 1 or 2.
EIA-485 Slave Address	An RTU address in the range 1 to 254. To disable transmission on the EIA-485 port, leave the value at 0.
BACnet MS/TP Port 3 Max Master	Number of BACnet masters allowed on the MS/TP network.

3.8.2 BACnet Server Configuration

To configure the BACnet server:

- 1 In the user interface, go to Configuration>BACnet.

The BACnet (Server) webpage displays.

Bacnet (Server)

[Bacnet Pics](#)

Device ID:

Device Name:

Description:

UDP Port: (0 = 47808)

APDU_Timeout: (seconds)

Number_of_APDU_Retries:

Bacnet COV Clients

IP Address

#1: 0.0.0.0

#2: 0.0.0.0

#3: 0.0.0.0

#4: 0.0.0.0

Bacnet BBMD-BDT

FDS IP Address: 10.0.0.219:0 Mask: 32 (FFFFFFFF)

	IP Address	Port	Mask (1-32)
(Primary) #1	<input type="text" value="0.0.0.0"/>	<input type="text" value="0"/>	<input type="text" value="0"/>
#2	<input type="text" value="0.0.0.0"/>	<input type="text" value="0"/>	<input type="text" value="0"/>
#3	<input type="text" value="0.0.0.0"/>	<input type="text" value="0"/>	<input type="text" value="0"/>
#4	<input type="text" value="0.0.0.0"/>	<input type="text" value="0"/>	<input type="text" value="0"/>

Figure 3.20 BACnet Server Configuration

- 2 Enter the following settings for the BACnet server:
 - a Enter the Device ID assigned by the user.
 - b Type a Device Name in that field. This name can be up to 40 characters in length.
 - c Type a Description in that field. This description can be up to 40 characters in length.
 - d Type the UDP port number in that field.

These fields are described in [Table 3.9 on page 47](#).

Table 3.9 BACnet Server Fields

Field	Description
Device ID	A numeric value that uniquely identifies each BACnet Device on the network.
Device Name	An alphanumeric value for BACnet discovery and integration that you assign to the unit indicated in the Device ID field.
Description	An alphanumeric value of your choice that provides more details about the device.
UDP Port	User datagram protocol port. Used by applications to send messages to a device (in this case, the Protocol Converter). The default port is 0=47808. If you want to use a specific port for security reasons, enter a new port number in this field.
APDU_Timeout	Application Protocol Data Units timeout. Amount of time, in seconds, that the Protocol Converter waits before considering any slave device as offline after a power up.
Number of APDU Retries	The number of times the Protocol Converter tries to connect with a BACnet slave device.
BACnet PICS link	This link displays the protocol implementation conformance statement (PICS). The PICS Web page shows general BACnet capabilities of the device (for example, available LAN options). An example of a BACnet PICS page is shown in Figure 3.21 .

BACnet interoperability building blocks supported (Annex K):
 Data Sharing - ReadProperty-B DS-RP-B WriteProperty-B

Bacnet Objects:

Analog Input
 AI:1 Register #1 Data or BI:1 Register #1 Data
 ..
 AI:1024 Register #1024 Data or BI:1024 Register #1024 Data

Property Identifiers Supported:

BACnet_Present_Value	BACnet_Object_Identifier	BACnet_Object_Name	BACnet_Object_Type
BACnet_Out_Of_Service	BACnet_Units	BACnet_Status_Flags	BACnet_Event_State
BACnet_Update_Interval	BACnet_Time_Delay(write)		

Bacnet Device Objects:

BACnet_Object_Identifier	BACnet_Object_Name	BACnet_Object_Type	BACnet_System_Status
BACnet_Vendor_Name	BACnet_Vendor_Id	BACnet_Model_Name	BACnet_Firmware_Revision
BACnet_App_Software_Revision	BACnet_Location	BACnet_Description	BACnet_Protocol_Version
BACnet_Conformance_Class	BACnet_Services_Supported	BACnet_Object_Types_Supported	BACnet_Object_List
BACnet_Max_APDU	BACnet_Segment_Supported	BACnet_Segment_Timeout	BACnet_APDU_Timeout
BACnet_APDU_Retries	BACnet_Bindings		

Data Link Layer options:

BACnet IP, (Annex J)

Character sets supported:

ANSI X3.4

Figure 3.21 Example BACnet PICS Page

3.8.3 SNMP

The SNMP Server configuration page allows you to set the System Name (displayed on the home page), System Contact, and System Location. You can also set up communities that allow multiple SNMP systems to access the Protocol Converter.

Note: To set up communities, you must know the IP address of the SNMP Management System and the Community String. If necessary, contact your Technical Support department to obtain the IP Address and Community String.

To configure the SNMP server:

- 1 In the user interface, go to Configuration>SNMP.

The SNMP (Server) webpage displays.

Figure 3.22 SNMP Server Configuration

- 2 Configure the SNMP server as described in [Table 3.10](#).

Table 3.10 SNMP Configuration Fields

Field	Description
System Name	An alphanumeric name you assign to the Protocol Converter for SNMP system integration.
System Contact	The person or organization responsible for the Protocol Converter.
System Location	An alphanumeric description of the Protocol Converter's location.
Get Community Name	The name or type of password used by the SNMP server for Get communications.
Set Community Name	The name or type of password used for the SNMP server that is writing to the Protocol Converter.
Trap Community Name	The name or type of password used by the SNMP server for Trap communications.
Trap Destination IP Address	Enter up to four IP addresses to indicate where the Protocol Converter should send Trap messages.

3.8.4 SMTP (Email)

Use the SMTP configuration section to set up the Protocol Converter's communication to email recipients. The Protocol Converter can send email to up to four recipients. Recipients can include an exchange server using a distribution list, an email account, or a cell phone. The Protocol Converter can also communicate via ESMTP (Authenticated) to mail servers requiring a login name and password.

To configure SMTP:

- 1 In the user interface, go to Configuration>SMTP/DNS.

The SMTP webpage displays.

SMTP

Submit Changes

Access Type: None LAN

Primary DNS Server:

Secondary DNS Server:

Mail (SMTP) Server:

Mail Sender Address:

Mail Subject:

Mail Recipient (1):

Mail Recipient (2):

Mail Recipient (3):

Mail Recipient (4):

SmtP Authentication: None Plain Login

SmtP Username:

SmtP Password:

Mail Server DNS address logged for: "" 0.0.0.0

Mail Server Dns TTL: 0

Emails Pending: 0 Emails Sent: 0

Figure 3.23 SMTP Configuration

- 2 Configure SMTP communication as described in Table 3.11 on page 50.

Table 3.11 SMTP Configuration Fields

Field	Description
Access Type	Select None if email is not to be used or to temporarily disable. Select LAN to enable email notification.
Primary DNS	The first IP address used to communicate to a DNS server.
Secondary DNS	The second IP address used to communicate to a DNS server.
Mail (SMTP) Server	The IP address or host name to the mail server being used by the Protocol Converter.
Mail Sender Address	The email address used by the Protocol Converter to communicate to the mail server.
Mail Subject	Description to be displayed on the email notification subject line.
Mail Recipient (1-4)	The address for an email account, cell phone, or distribution list.
SMTP Authentication	<ul style="list-style-type: none"> • None is used for no username or password being required. • Plain is used for standard Username and password authentication. • Login is used for certain mail servers. Do not use this unless instructed by your IT department.
SMTP Username	If you choose the Login radio button for SMTP Authentication, enter the username in this field.
SMTP Password	If you choose the Login radio button for SMTP Authentication, enter the password in this field.

OPERATION

This chapter describes how to view the status of the slave devices (registers) configured to the Protocol Converter.

To view the status of the slave devices configured to the Protocol Converter:

- 1 Log in to the Protocol Converter (see 3.2., “Logging in to the Protocol Converter” on page 26 for instructions).

The Home page, which is titled Devices, displays a list of configured slave devices and their status. Figure 4.1 shows an example of the Devices page.

Raptor RLE Technologies

Devices | Registers | Identity | Device Configuration | Configuration | Refresh | Help

Protocol Converter THU 08/26/10 10:37:48

#	Name	Access
1	SeaHawk LD5100	Modbus485
2	SeaHawk LD2000	Modbus/TCP
3	SeaHawk LD1500	Modbus/TCP
4	Falcon FMS-CCCC-N-24	Modbus/TCP
5	Falcon FMS-AAAA-Y-24	Modbus/TCP
6	SeaHawk LD1500	SNMP
7	SeaHawk LD2000	SNMP
8	Falcon F110	SNMP
9	Falcon F1000	SNMP
10	Falcon F3400	SNMP
11	Falcon FMS-CCCC-N-24	SNMP
12	Falcon 8126	SNMP
13	Falcon 2006	SNMP
14	Falcon FMS20U	SNMP
15	Falcon FMS20	SNMP
16	Falcon FMS32	SNMP
17	FalconLite (FLS8)	SNMP
18	Falcon FMS-X-N-24	SNMP
19	Falcon FMS-ABCM-N-24	SNMP
20	Geist R50	SNMP
21	Falcon F110	Modbus/TCP
22	Falcon F1000	Modbus/TCP
23	Falcon F3400	Modbus/TCP
24	Falcon FMS-CCCC-N-24	Modbus/TCP
25	SeaHawk LD1500	Bacnet
26	SeaHawk LD2000	Bacnet
27	Falcon 8126	Bacnet
28	Falcon 2006	Bacnet
29	Falcon FMS20U	Bacnet
30	Falcon FMS20	Bacnet
31	Falcon FMS32	Bacnet
32	FalconLite (FLS8)	Bacnet

FDS-PC ©2010 RLE Technologies

Figure 4.1 Protocol Converter Devices (Home) Page

- Identify any devices that need attention by interpreting the color code. Figure 4.2 defines each color.

Color		Meaning
(Green)		Register is communicating properly
(Red)		Register has reached an alarm threshold
(Orange)		Register is offline - problems with the communications
(Yellow)		Register - pending alarm
(Yellow)		IP device - no arp response

Figure 4.2 Color Codes for the Home Page

Note: The color code is also available in the Help section of the Protocol Converter interface.

- Click on an individual device number to view individual information being polled from that device to the Protocol Converter.

#	Name	Access
1	SeaHawk LD5100	Modbus/485
2	SeaHawk LD2000	Modbus/TCP
3	SeaHawk LD1500	Modbus/TCP
4	Falcon FMS-CCCC-N-24	Modbus/TCP
5	Falcon FMS-AAAA-Y-24	Modbus/TCP
6	SeaHawk LD1500	Modbus/TCP

Device #1: I/O Module

#	Name	Device	Register	Value	Age
1	AC1 Current	1	40001	0	?
2	AC2 Current	1	40003	0	?
3	Hallway Temperature	1	40005	0	?
4	Room Humidity	1	40007	0	?
5	Room Temperature	1	40009	0	?
6	Underfloor Temperature	1	40011	0	?
7	AC1 Airflow	1	10001	0	?

Figure 4.3 Register Status Example

- Visit the RLE website for documentation or troubleshooting information by clicking on the “(Copyright Date) RLE Technologies” link in the bottom right hand corner of the webpage.

MODBUS COMMUNICATIONS

This chapter describes the Modbus communication protocol as supported by the Protocol Converter Wireless System. The content includes details and information on how to configure the Protocol Converter for communications via Modbus network.

5.1. Implementation Basics

The Protocol Converter is capable of communicating via the half-duplex EIA-485 serial communication standard. The Protocol Converter is configured to act as a slave device on a common network. The EIA-485 medium allows for multiple devices on a multi-drop network. The Protocol Converter is a slave only device and will never initiate a communications sequence.

5.1.1 Modes of Transmission

The Modbus protocol uses ASCII and RTU modes of transmission. The Protocol Converter supports only the RTU mode of transmission, with 8 data bits, no parity and one stop bit. Every Modbus packet consists of four fields:

- ◆ Slave Address Field
- ◆ Function Field
- ◆ Data Field
- ◆ Error Check Field (Checksum)

5.1.1.1 Slave Address Field

The slave address field is one byte in length and identifies the slave device involved in the transaction. A valid address range is between 1 and 254. The slave address is set on the **Modbus Device** section of the Configuration page.

5.1.1.2 Function Field

The function field is one byte in length and tells the Protocol Converter which function to perform. The supported functions are 03 (Read 4xxxx output registers).

5.1.1.3 Data Field

The data field of the request is a variable length depending on the function. The data fields for the Protocol Converter are 16-bit registers, transmitted high order byte first (big-endian)

5.1.1.4 Error Check (Checksum) Field

The checksum field lets the receiving device determine if the packet has transmission errors. The Protocol Converter RTU mode uses a 16-bit cyclic redundancy check (CRC-16).

5.1.2 Exception Responses

If a Modbus master sends an invalid command to the Protocol Converter or attempts to read an invalid register, an exception response is generated. The response packet will have the high order bit of the function code set to one. The data field of the exception response contains the exception error code.

Table 5.1 Exception Codes

Code	Name	Description
01	Illegal Function	The function code is not supported
02	Illegal Data Address	Attempt to access an invalid address
03	Illegal Data Value	Attempt to set a variable to an invalid value

5.2. Packet Communications for the Protocol Converter

This section covers the registers with the name and a brief description of each.

5.2.1 Function 03: Read Output Registers

To read the Protocol Converter parameter values, the master must send a Read Output Registers request packet.

The Read Output Registers request packet specifies a start register and the number of registers to read. The start register is numbered from zero (40001 = zero, 40002 = one, etc).

Table 5.2 Read Output Registers Packet Structure

Read Registers Request Packet	Read Registers Response Packet
Slave Address (1 byte)	Slave Address (1 byte)
03 (Function code) (1 byte)	03 (Function code) (1 byte)
Start Register (2 bytes)	Byte count (1 byte)
# of registers to read (2 bytes)	First register (2 bytes)
CRC Checksum (2 bytes)	Second register (2 bytes)
	...
	CRC Checksum (2 bytes)

Table 5.3 Output Registers

Register	Name	Description	Units	Range
40001	Integer Output	Register for Integer data	uint16	0-65535
42001	Float Output * two registers need	Register for Float data	Uint32	0-65535

5.3. RTU Framing

The example below shows a typical Query/Response from an Protocol Converter Wireless System.

Table 5.4 Response Sample

Slave Address	Function Code	Count Bytes of Data	Register Data Msb	Register Data Lsb	Register Data Msb	Register Data Lsb	Register Data Msb	Register Data Lsb	CRC 16 "Lsb"	CRC 16 "Msb"
02	04	06	00	00	00	00	00	01	B5	A3

Slave address 2 responds to Function Code 4 with six bytes of hexadecimal data and ends with CRC16 checksum.

Register Values:

40001 = 0000 (hex)

40002 = 0000 (hex)

40003 = 0001 (hex)

Notes:



LOADING FIRMWARE AND CONFIGURATION FILES

You can perform the following firmware and configuration related operations for the Protocol Converter:

- ◆ Load different firmware to the Protocol Converter. RLE occasionally updates the firmware to add enhancement or fix errors. Firmware updates are available on the RLE website at www.rletech.com. Download appropriate firmware to an accessible place to upload to the Protocol Converter via MIME or TFTP through a LAN connection. Firmware files have a .bin extension.
- ◆ Make a backup of your custom configuration or copy the same configuration to several Protocol Converters rather than having to change the settings manually on each unit. The configuration settings are contained in a .cfg file.
- ◆ Make a copy of the configuration for a device so you can copy that configuration to other, identical devices. The configuration settings for a device are contained in an .xml file.

A.1. Loading Flash Firmware Using MIME

To update the firmware for the Protocol Converter using the MIME (multipurpose Internet mail extensions) standard:

- 1 Go to the RLE website Resources page at <http://www.rletech.com/resources/>.
- 2 Scroll down to the Raptor section and locate the firmware (a .bin file) for the Protocol Converter. *Using the same filename*, save it to a local disk.

IMPORTANT Do not change the name of the firmware file when you save it. Otherwise, the Protocol Converter will not recognize the file.

- 3 In the Protocol Converter's user interface, go to Configuration>System.

The System webpage displays.

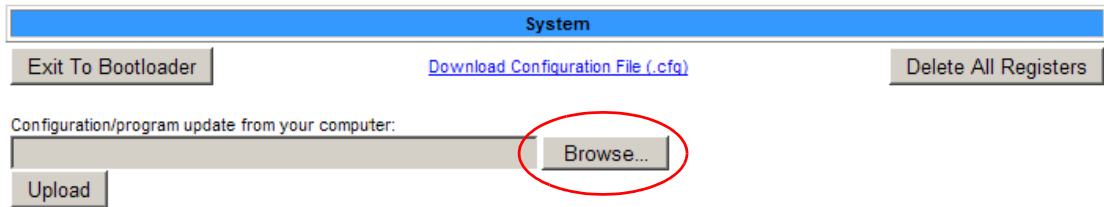

Figure A.1 System Page—Load Flash Firmware

- 4 Click the Browse button.
- 5 Locate and choose the firmware file (.bin) that you saved from the RLE website.

The path and name of the firmware file (.bin) displays in the field to the left of the Browse button.

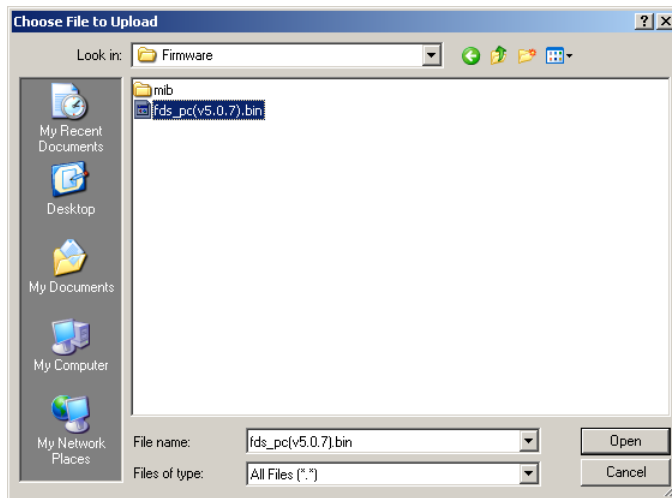

Figure A.2 Choosing a Firmware File

- 6 Click the Upload button.

The firmware is loaded while the Protocol Converter displays a message confirming that it is loading the new file.

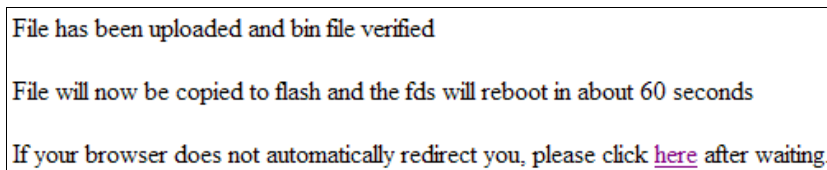

Figure A.3 Firmware Load Messages

When the file is loaded, the Protocol Converter reboots itself. The reboot process takes approximately 60 seconds. After the reboot, the Home page displays.

- 7 Click the Identity link on the top bar and verify that the new file has been loaded.

PCB Version	PCB Rev. E
CPU	MCF5270
Firmware Version	FDS_PC V5.0.7
Program Size	349648
Bootloader Version	FDSBOOT V5.0.2

Figure A.4 Identity Link Showing Current Firmware Version

A.2. Loading Flash Firmware Using TFTP

Loading firmware via TFTP (trivial file transfer protocol) requires a TFTP client. It may be possible to download a free license TFTP client from the internet. Consult your IT department to determine a compatible client program.

Before updating the firmware, the firmware flash application must be exited and then erased as follows:

- 1 Verify that your PC and the Protocol Converter are on the same subnet (LAN) so the TFTP client can access the Protocol Converter.
- 2 Go to Configuration>System.

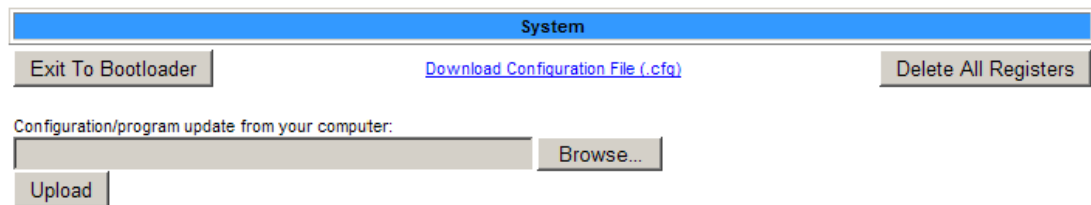

Figure A.5 System Page

- 3 Click the Exit to Bootloader button.

Once exited, a bootloader webpage displays at the IP address of the Protocol Converter.

A Loading Firmware and Configuration Files

RLE CF BOOTLOADER/FDS	
Firmware Version	FDSBOOT V5.0.2
MAC Address	00:90:5B:00:00:C8
IP Address	10.0.0.219
Net Mask	255.255.255.0
Def Route	10.0.0.1
TCP Max Seg Size	1436
sysUpTime	0 days 0 hrs 0 mins 15 secs
Current Time	08/19/10 11:12:22
Flash Application	FDS_PC V5.0.6
Flash Appl. Size	349440
Restart Timer	105

Figure A.6 Bootloader Page

4 Click on the “Erase Flash” button.

Note To erase the flash, a special username and password are required. The username is **fds** (all lowercase), and the password is **rlc2tech** (all lowercase). These cannot be changed.

The Flash is erased.

5 Open your TFTP client. Configure the client as follows.

a Host = Protocol Converter IP Address

b Port = 69

c Block Size = 64, 128, 256, 512, or 1024

Note The file must be sent in BINARY (not ASCII).

6 Send or PUT the firmware file to the Protocol Converter. It may take ~10 seconds for the firmware upload to begin. This will put the new firmware into effect.

7 After one minute, refresh the Protocol Converter webpage. Notice that the Flash Application field now contains the latest firmware. Click the “Start Application” button to reboot the unit.

A.3. Saving a Configuration (.cfg) File

If you want to make a backup of your custom configuration or copy the same configuration to several Protocol Converters rather than having to change the settings manually on each unit, save the configuration (.cfg) file. To save the .cfg file:

- 1 In the user interface, go to Configuration>System.

The System webpage displays.

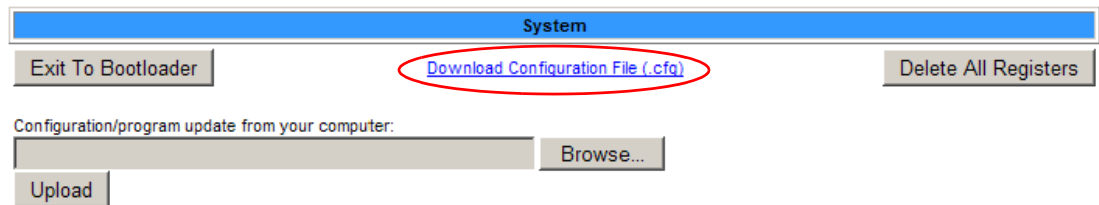

Figure A.7 System Page—Download Configuration File

- 2 Click the Download Configuration File .cfg link.

A download window opens so you can save the current system configuration.

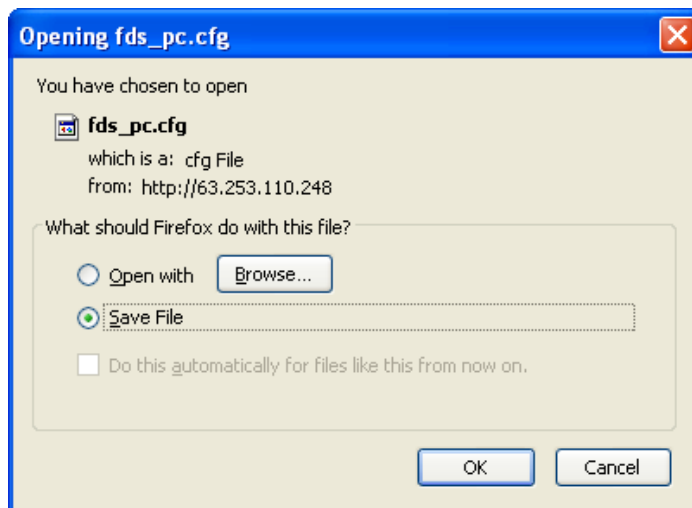

Figure A.8 Example Download .cfg

- 3 Select the Save File radio button and then click the OK button. Select the location and name for the file (**do not change the .cfg extension**). Click the Save button.

The file is saved to the location and with the name you specified.

A.4. Loading a Configuration (.cfg) File

Once you have saved a configuration file as described in A.3., “Saving a Configuration (.cfg) File” on page 61, you can load that file to the same Protocol Converter or other Protocol Converters.

To load a configuration file (.cfg) to the Protocol Converter:

- 1 Ensure that the .cfg file you want to load is on a local drive.
- 2 On the Protocol Converter interface, go to Configuration>System.

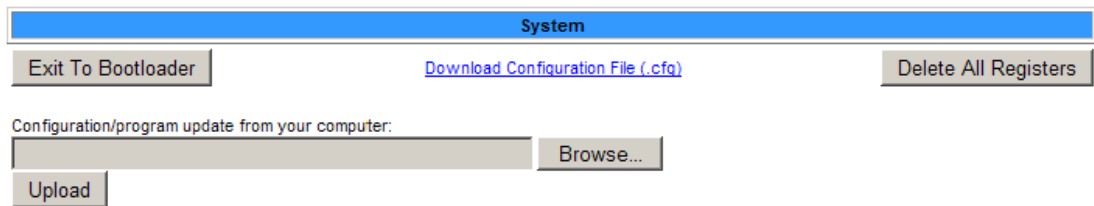

Figure A.9 System Page

- 3 Click the Browse button.
- 4 Locate and choose the configuration file (.cfg) that you saved.

The path and name of the configuration file (.cfg) displays in the field to the left of the Browse button.

- 5 Click the Upload button.

The configuration file is loaded while the Protocol Converter displays a message confirming that it is loading the new file. When the file is loaded, the Protocol Converter reboots itself. The reboot process takes approximately 60 seconds. After the reboot, the Home page displays.

A.5. Saving a Device Configuration (.xml) File

When you have configured a specific device using the Protocol Converter's interface, you can save that device configuration and load it to another device of the same type. This procedure may not work in all cases; some manufacturers use the same register set across different models of the same type of device, and others do not.

To save a device configuration:

- 1 Click the Device Configuration link in the top bar.



Figure A.10 Device Configuration Link in Top Bar

The Device Configuration webpage displays.

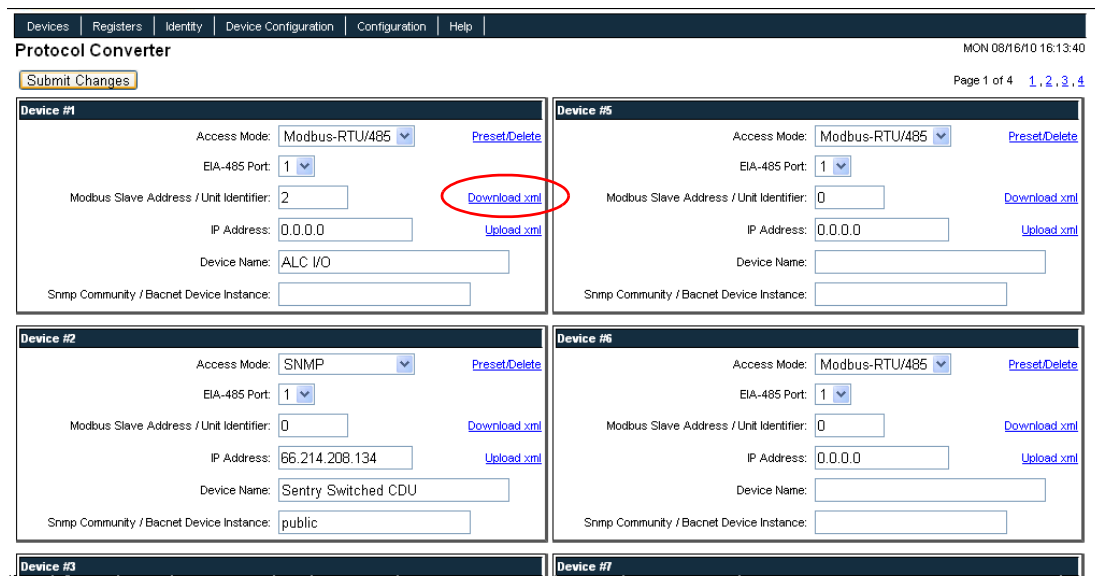

Figure A.11 Device Configuration Webpage

- 2 Locate the configuration box for the device whose configuration you want to save.
- 3 Click the Download XML link in that device's configuration box.

- ◆ **Internet Explorer:** The contents of the file are opened in a browser window. You must copy and paste the contents into a text editor (such as Notepad), then save the file with an .xml extension.
- ◆ **Firefox:** A dialog box opens to display the file name that is automatically assigned to the device. You can choose to open or save the file. Save the file.

When you have saved the .xml file, it can be uploaded to other devices of the same type. See "Loading a Device Configuration (.xml) File" on page 64 for instructions.

A.6. Loading a Device Configuration (.xml) File

An .xml file that you have saved using the Protocol Converter’s user interface can be loaded to another device. This procedure may not work in all cases; some manufacturers use the same register set across different models of the same type of device, and others do not.

To load an .xml file to a device:

- 1 Click the Device Configuration link in the top bar.



Figure A.12 Device Configuration Link in Top Bar

The Device Configuration webpage displays.

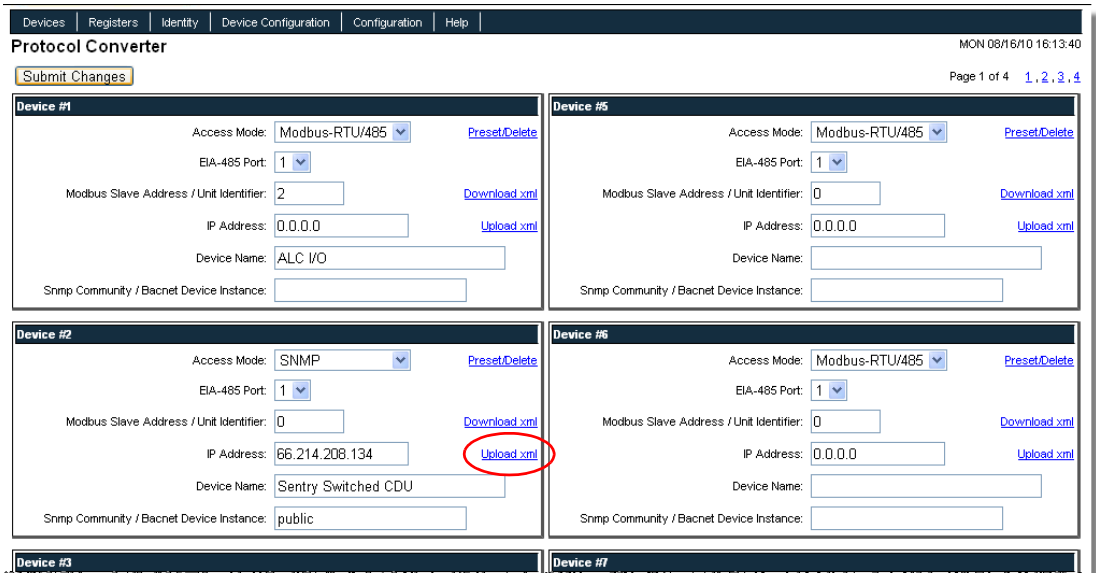

Figure A.13 Device Configuration Webpage

- 2 Locate the configuration box for the device to which you want to upload a saved .xml file.
- 3 Click the Upload XML link in that device’s configuration box.

The XML Upload dialog displays in a secondary browser window.

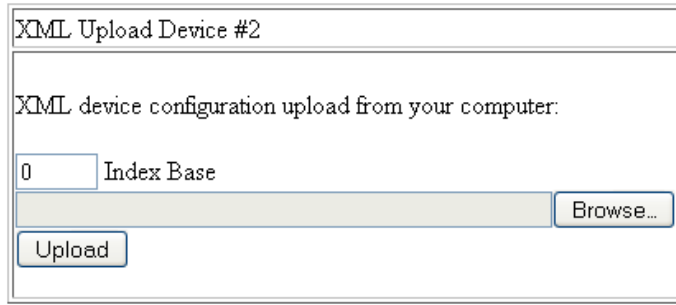

Figure A.14 XML Upload Dialog

- 4 Browse for the .xml file you saved. Select the file, then in the Index Base box, indicate the index (register) number you want to start from when the upload occurs.
- 5 Click Upload.

One of three message displays:

- ◆ XML file upload complete.
- ◆ XML file cannot be upload - index base was not specified. If this occurs, retry the operation and specify a register number in the Index Base box.
- ◆ File has been uploaded - but type is unknown. Proceed to step 6.

- 6 If you want to revert to the preset registers or delete all registers, or if you attempted to upload an unknown file type to a device, click the Preset/Delete link for that device.

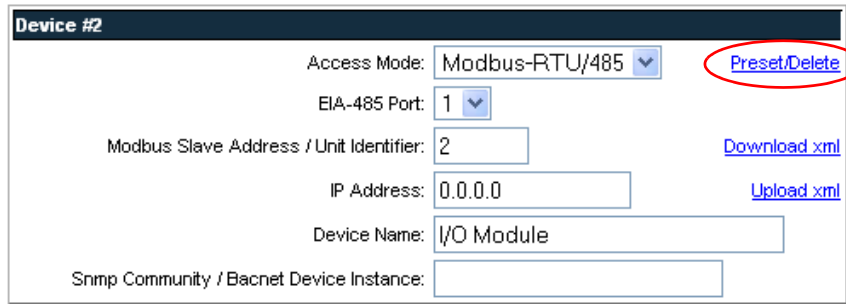

Figure A.15 Preset/Delete Link on Device Configuration Webpage

The Preset/Delete dialog displays in a secondary browser window.

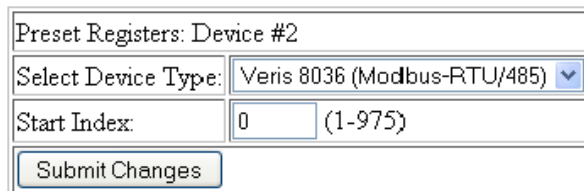

Figure A.16 Preset/Delete Dialog

7 Select one of two items from the drop-down:

Preset Registers: Device #2

Select Device Type: Veris 8036 (Modbus-RTU/485)

Start Index:

Submit Changes

Figure A.17 Drop-Down for Preset/Delete Dialog

8 Revert to the preset registers or delete all register information as follows:

- ◆ To revert to the preset values, indicate a Start Index number. This is the number of the register at which you want to begin the preset operation.

If you choose to preset the register values, the following message displays when the operation is complete:

```
8036 registers preset at index 1
```

- ◆ If you choose Delete Device/Registers, all device information will be deleted. **Use this option with caution.**

You do not need to enter a Start Index number when deleting all registers.

If you choose the delete option, the following message displays when the operation is complete:

```
Device and Registers deleted
```

B

TROUBLESHOOTING

Table B.1 Troubleshooting the Protocol Converter

Problem	Action
Control Panel will not Power Up	<ol style="list-style-type: none"><li data-bbox="771 926 1456 1083">1 Check with a DVM (Digital Volt Meter) for AC or DC input power on the lower left hand terminal block on the Protocol Converter. If no voltage is present at terminal block, check the circuit (breaker) or power supply the Protocol Converter control panel is powered by. If voltage is present, go to step 2.<li data-bbox="771 1104 1446 1178">2 Contact RLE Technologies for unit replacement and/or evaluation. If voltage is present, contact RLE Technologies for further troubleshooting.

Table B.1 Troubleshooting the Protocol Converter (continued)

Problem	Action
Unable to see the web page	<ol style="list-style-type: none"> <li data-bbox="724 285 1412 422">1 Verify that the Protocol Converter is powered up and running. You will see lights on the RJ45 (Ethernet) port illuminated and flashing. If no lights are illuminated on the unit, check for power to the unit. If lights are illuminated and flashing, go to step 2. <li data-bbox="724 436 1412 678">2 Connect a serial cable up to the Protocol Converter console port. Once connect and your terminal emulation program is running, type ip and then press enter, this will display the current IP address set to the unit. Verify it is the correct address. The same can be done for viewing the Net Mask number by entering nm and then press enter. For viewing the Default Gateway type dg and then press enter. Correct any information that is wrong. If the information is correct, go to step 3. <li data-bbox="724 693 1412 993">3 With the serial cable connected and your terminal emulation program open, you can enter an address to have the Protocol Converter ping to. Get a known good address and the type ping <one space> ip address and then press enter. Example: ping 192.168.1.1, if a ping response is not established, get with the IT department and make sure the patch cord being used is good, and then have the network switch port checked to make sure it is activated. If a ping response is established, call your local sales representative or RLE Technologies technical support department.
Slave units are showing loss of communication.	<ol style="list-style-type: none"> <li data-bbox="724 1014 1412 1087">1 Check the Device Configuration in the Protocol Converter and make sure the proper addressing is assigned. <ol style="list-style-type: none"> <li data-bbox="756 1108 1412 1182">a Modbus-RTU/485: The device address is set to the proper RTU address and the 485 communications line is wired properly. <li data-bbox="756 1203 1412 1339">b Modbus TCP/IP: The Proper device address and IP address has been assigned. Modbus TCP/IP communications requires port 502 of that IP address to be enabled/open. Check with IT to make sure there is not a firewall or port blocking on port 502. <li data-bbox="756 1360 1412 1476">c SNMP: Check the IP address and community that was configured on the Protocol Converter for communication. Port 161 of the IP address is used for SNMP get data. Check to make sure this port is open. <li data-bbox="756 1497 1412 1623">d BACnet: Check the IP address and device number configured on the Protocol Converter. The default port used for BACnet data is port 47808. Check with IT to make sure this port is open for communication on the network.



TECHNICAL SPECIFICATIONS

Table C.1 Technical Specifications

Power	24VAC @ 600mA max, 50/60Hz, 24VDC @ 600mA max.	
Communications Ports		
	Ethernet	10/100 BASE-T, RJ45 connector; 500VAC RMS isolation
	EIA-232	DB9 female connector; 9600 baud; No parity, 8 data bits, 1 stop bit
	EIA-485 (Dual Port Protocol Converter contains 3 EIA-485 ports)	1200, 2400, 9600 or 19200 baud (selectable); Parity: none, even or odd, 8 data bits, 1 stop bit. Port 2 is configurable for half-duplex (2-wire) or full-duplex (4-wire)
Protocols		
	TCP/IP, HTML, TFTP, SNMP	V1: V2C MIB-2 compliant; NMS Manageable with Get
	Modbus (EIA-485)	Modbus Master/Slave; RTU mode; Supports Master codes 01, 02, 03, 04 and Slave code 03
	Modbus TCP/IP UDP/IP	Modbus Master/Slave; TCP/IP transmission protocol
	BACnet/IP	ASHRAE STD 135-2004 Annex J; Port 3 of Dual Port Protocol Converter is BACnet MS/TP capable (Slave only)
	SMTP (email)	Supports Client Authentication (plain and login); compatible with ESMTP servers
	Terminal Emulation	VT100 compatible (for configuration and diagnostics only)
Protocols In	SNMP, Modbus TCP/IP & RTU, BACnet	
Protocols Out	SNMP, Modbus TCP/IP & RTU, BACnet; BACnet MS/TP (Port 3 of Dual Port Protocol Converter only)	
Login Security		
	Web Browser Access (Ethernet)	1 Web password Read Only; 1 Web password Read/Write
	Terminal Emulation Access	None
Maximum Number of Units/Modules/Nodes	32	

Table C.1 Technical Specifications (continued)

Maximum Number of Registers/OIDs/Instances		1,024
Indicators		
	Status	1 Red: flashing=boot-up sequence; solid=alarm condition
	EIA-485 Transmit and Receive	1 Green Transmit; 1 Green Receive (additional LEDs for Dual Port Protocol Converter)
Operating Environment		
	Temperature	32°F to 122°F (0°C to 50°C)
	Humidity	5% to 95% RH (non-condensing)
	Altitude	15,000ft (4572m) max.
Storage Temperature		-4°F to 185°F (-20°C to 85°C)
Mounting		Desktop or 19" (48.26cm) rack mount
Dimensions		9.8"W x 5.3"D x 1.8"H (248mmW x 135mmD x 46mmH)
Weight		2.32.lb (1.05kg)
Certifications		CE; ETL listed: conforms to UL STD 61010-1, EN STD 61010-1; certified to CSA C22.2 STD NO. 61010-1; RoHS compliant