

Spot Detector Quick Start Guide

designed for use with SD, SD-Z1, SD-Z, SD-RO1, & SD-RO2 products

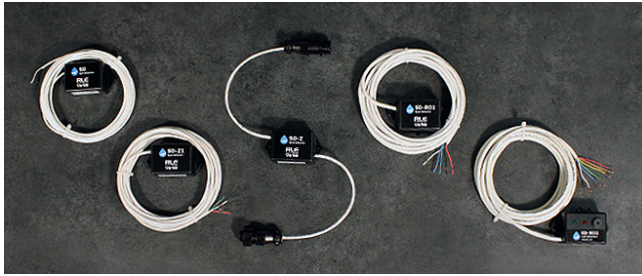

Thank you for purchasing a SeaHawk spot detector. This guide describes how to install all models of spot detectors available from RLE Technologies. Before you install a spot detector, check our

website - www.rletech.com - to ensure you are using the most recent version of our documentation.

If you need further assistance, please contact RLE at support@rletech.com.

SeaHawk

v07.21

RLE
Technologies

© Raymond & Lae Engineering, Inc. 2011. All rights reserved. RLE® is a registered trademark and Seahawk™, Falcon™, and Raptor™ are trademarks of Raymond & Lae Engineering, Inc. The products sold by RLE Technologies, 104 Racquette Dr., Fort Collins, CO 80524 are subject to the limited warranty, limited liability, and other terms and conditions of sale set forth at <http://www.rletech.com/>.

General Installation Instructions

While the instructions to mount each spot detector to the floor are the same, each model of SD connects differently with its controller. Follow these instructions to mount your spot detector to the floor; then continue to the directions specific for your SD.

1. Determine the spot detector's location
2. The angle of the sense probes can be adjusted to change the sensitivity of the SD. The closer the probes are to the floor, the smaller the quantity of water required to trigger the sensor. Adjust the sense probes to the desired height. Be sure the probes don't touch each other.

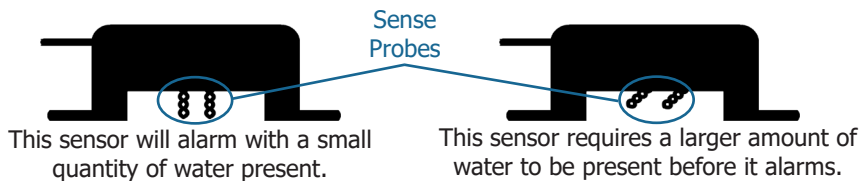

3. Ram set 6/32 threaded studs in the floor on 2.5" centers or apply mastic.
4. Place the spot detector over the studs or mastic and secure.

From this point, each spot detector's installation varies a bit. Refer to the instructions for your particular unit.

SD

The SD is designed to primarily function with RLE controllers, specifically the FMS and the LDRA6. The SD functions like a switch - the circuit remains open until a leak is detected. The sense probes detect a leak, which causes the circuit to close, which then triggers an alarm. A power supply connected to the SD must be an isolated power supply - RLE recommends either RLE part number PSWA-DC-24-ST or WA-AC-24-ST. These power supplies are sold separately and are available from RLE. If the SD is operating on 12-36VAC power, the circuit will reset and open automatically once the leak is no longer present. If the SD is operating on 18-36VDC power, the circuit must be manually reset after the leak is cleared. To do this, you must break power to the device, which will reset the circuit. Even if the water leak is no longer present, power must be broken to manually reset the DC-powered SD.

The SD comes with a two-wire open lead that allows it to be wired directly to the controller's terminal block. Connect the white/red and black leads to the appropriate terminal blocks on the controller.

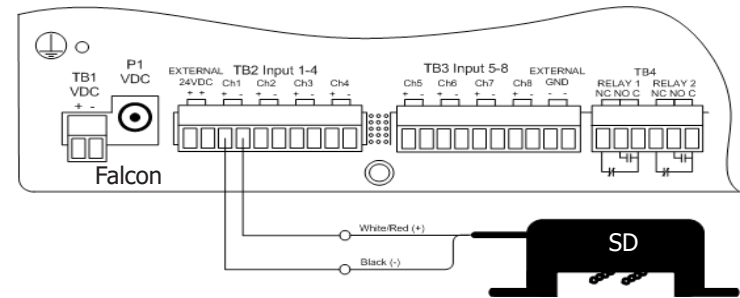

SD-Z1

The SD-Z1 is a single zone spot detector, designed for zone leak detection systems including the LD310, LD1000, and LDRA6. RLE recommends using only one SD-Z1 per zone.

The SD-Z1 comes with a four-wire open lead that allows it to be wired directly to the controller's designated terminal block. Connect the four wires - red, green, black, and white - on the SD-Z1 to the terminal block on the controller.

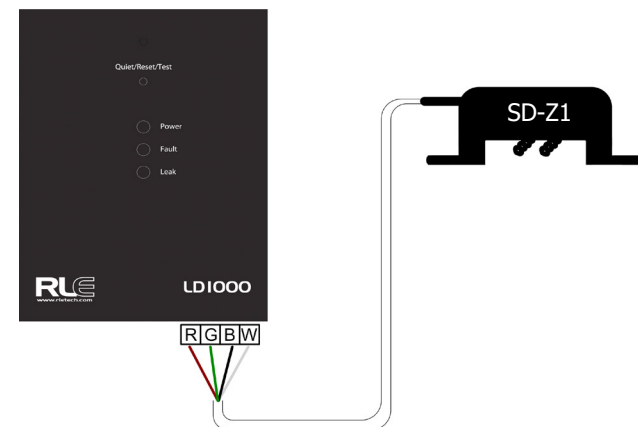

SD-Z

Designed to work with either zone or distance-read leak detection controllers, the SD-Z can also be connected to other SD-Z units or to sensing or non-sensing cable. When used with a distance-read system, the SD-Z simulates 50 feet of cable - 25ft. (7.62m) from the male connector to the SD-Z, and 25ft. (7.62m) from the SD-Z to the female connector.

Because a SD-Z cannot connect directly to a controller, leader cable and an EOL terminator are required for installation. RLE packages these components as an LC kit. If you're adding the SD-Z to an existing RLE leak detection system, additional leader cable and EOL may be unnecessary. Please check your supplies before you attempt to install the SD-Z.

When you connect RLE leak detection components, the male pins in the connectors should always point toward the controller. Therefore, connect the black connector with the pins to the control head, and place the EOL on the connector without pins.

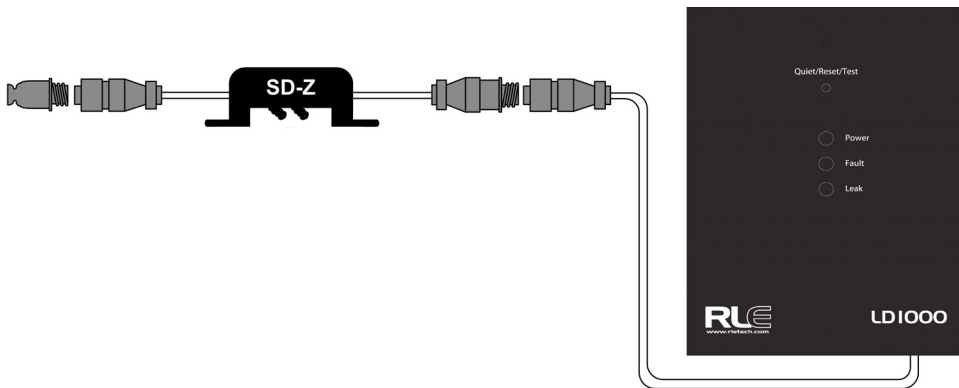

If the SD-Z is being added to an existing system - connected in a chain with other SD-Z devices or cable - undo the appropriate coupling, insert the SD-Z into the chain, and secure all connections.

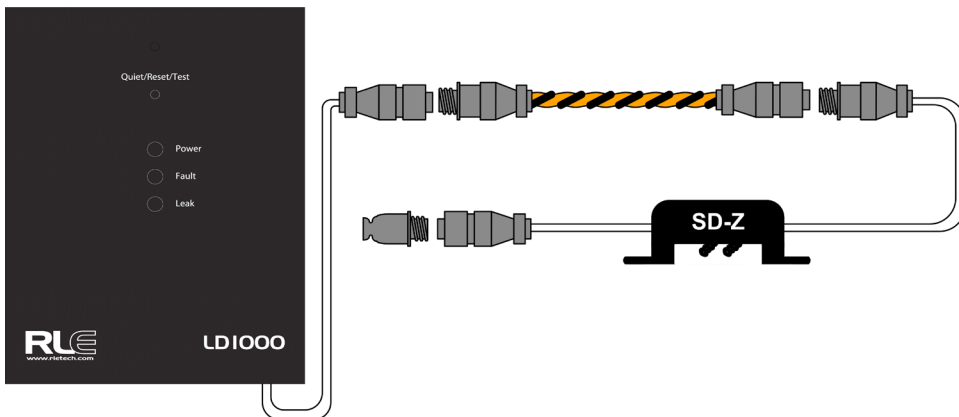

SD-RO1 and SD-RO2

The SD-RO1 and SD-RO2 are single zone spot detectors. The SD-RO1 has one generic relay output and the SD-RO2 has two generic relay outputs, LEDs, & an audible alarm. Use them with any product that accepts digital dry contact inputs.

The SD-RO1 and SD-RO2 require an isolated power supply, either RLE part number PSWA-DC-24 or WA-AC-24-ST. RLE sells these power supplies separately.

If the SD-RO1 or SD-RO2 are operating on 24VAC power, the circuit will reset and open automatically once a detected leak is no longer present. If the SD-RO1 or SD-RO2 are operating on 24VDC power, the circuit must be manually reset after a leak is detected and cleared. To do this, you must break power to the device, which will reset the circuit. Even if the water leak is no longer present, power must be broken to manually reset the DC-powered spot detector. The easiest way to accomplish this manual reset is to install a reset switch on either the positive or negative wire of the power supply that feeds into the SD-RO1 or SD-RO2.

To connect the SD-RO1 to a controller:

1. Connect the green (C) and white (N/O) or blue (N/C) leads to the alarm device.
2. Connect the black (-) and red (+) leads to the power source.

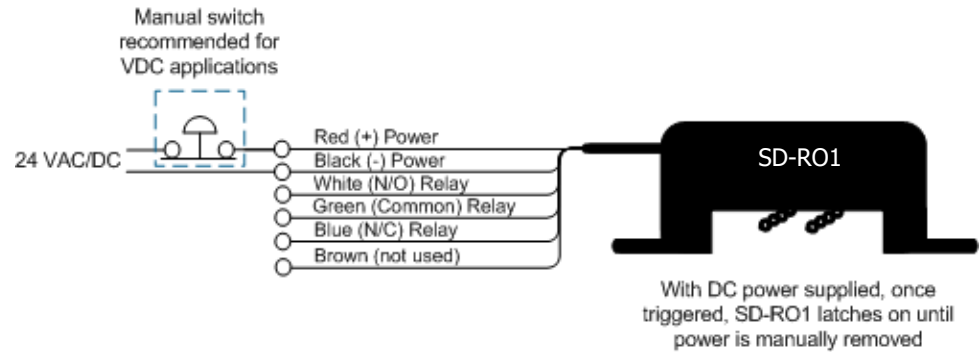

To connect the SD-RO2 to a controller:

1. Connect the green (C) and white (N/O) or blue (N/C) leads for the first relay output to the alarm device.
2. Connect the brown (C) and yellow (N/O) or orange (N/C) leads for the second relay output to the alarm device.
3. Connect the black (-) and red (+) leads to the power source.

